

# MC-7130-MP Marine Computer

*optimal marine platform with diverse interface connectivity*



- > High performance computing platform with 3rd gen Intel® Core™ i3 3120ME processor
- > Optimized solution with modularized NMEA interfaces
- > DNV and ABS certified
- > Trusted Platform Module provides data and hardware security integrated at the hardware level
- > Blistering fast graphics performance across 3 independent displays



## Overview

The MC-7130-MP marine computer is powered by the latest 3rd generation Intel® Core™ i3 3120ME processor. Optimized for ECDIS, these computers can serve in nearly any bridge role thanks to their comprehensive range of I/O and communications interfaces: eight NMEA 0183 terminals, four serial ports, four gigabit Ethernet ports, six USB 2.0 and three SuperSpeed USB 3.0 ports. The MC-7130-MP is designed to give unrivalled PC performance for a new level of flexibility and control for marine applications.

Designed with the highest quality and durability in mind, the marine-grade MC-7130-MP computer features a rugged chassis and vibration tolerance up to 1G, together providing a highly reliable platform that can easily tolerate the harsh environmental challenges of marine environments. Additionally, the MC-7130-MP's compact size

and low power consumption return a low heat profile that increases MTBF while simplifying integration into existing bridge systems or newly designed marine solutions.

Finally, the MC-7130-MP also offers convenient connectivity expansions via a single PCIe (x16) slot and two universal PCI slots, allowing users to install a variety of peripheral extensions for radar, PROFIBUS, VGA graphics, and more, allowing for direct consolidation of all input sources at a single hub.

The MC-7130-MP platform is optimized for use with the Windows XP Embedded, XP Professional, or Windows 7 operating systems, allowing users to choose the development environment most suitable for the application's needs.

## Appearance

### Front View

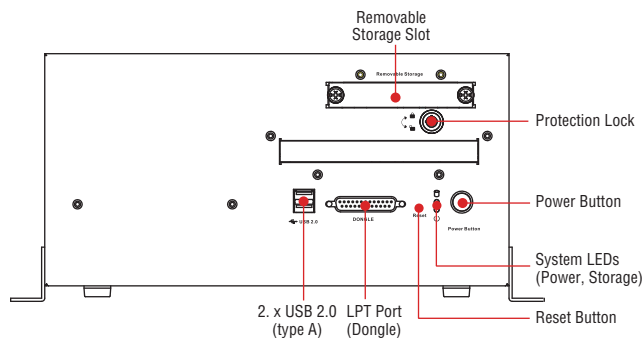

## Rear View

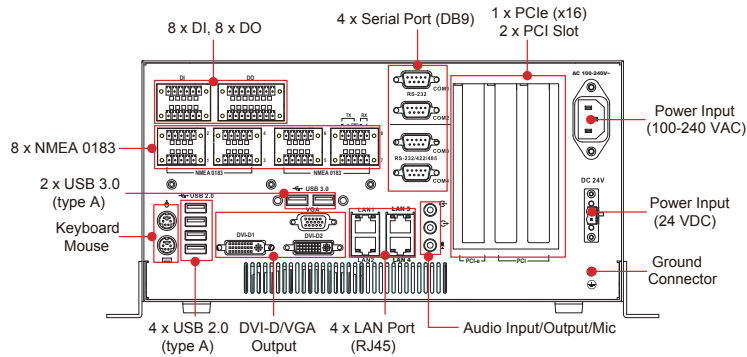

## Dimensions

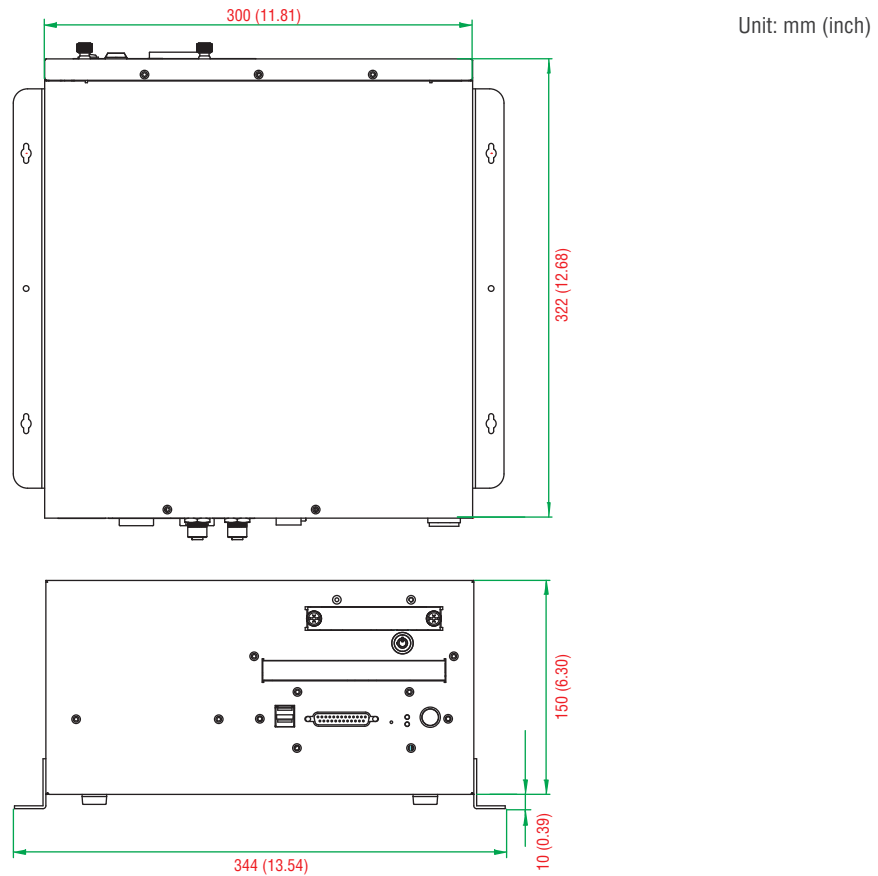

## Specifications

### Computer

**CPU:** Intel® Core™ i3-3120ME (BGA CPU package), dual core threaded 64 bit 2.4 GHz processor

**OS:** Windows 7, Windows XP SP3, Windows XP Embedded (must be installed by the user)

**System Chipset:** Intel® QM77 Express Chipset

**System Memory:** 16 GB capacity, 4 GB pre-installed: 2 slots of 8 GB DDR3-1066 204 pin SO-DIMM SDRAM

**USB:** USB 2.0 host x 6, USB 3.0 host x 2, Type A connectors

### Storage

#### Storage Support:

- 2 SATA 6 Gb/s ports for SSD/HDD
- 2 SATA 3 Gb/s ports for SSD/HDD

### Other Peripherals

**Audio:** Line in x 1, Line out x 1, Mic x 1

**KB/MS:** 2 PS/2 interfaces supporting standard PS/2 keyboard and mouse

**PCI Slots:** 2

**LPT Port:** 1

**PCIe x16 Slots:** 1

### Display

#### Display Interface:

- VGA Interface x 1: 15-pin D-Sub connector (female), with resolution up to 1920 x 1080
- DVI-D Interface x 2: 29-pin DVI-D connectors (female), with resolution up to 1920 x 1080, 60Hz (with reduced blanking)

**Graphics Controller:** Onboard Intel® HD 4000 graphics

### Ethernet Interface

**LAN:** 4 auto-sensing 10/100/1000 Mbps ports (RJ45)

**Magnetic Isolation Protection:** 1.5 kV built in

### Serial Interface

**Serial Standards:**

- 2 RS-232/422/485 ports, software-selectable (DB9 male)
- 2 RS-232 ports (DB9)
- 8 NMEA 0183 terminals (NMEA 2000 available on request)

### Serial Communication Parameters

**Data Bits:** 5, 6, 7, 8

**Stop Bits:** 1, 1.5, 2

**Parity:** None, Even, Odd, Space, Mark

**Flow Control:** RTS/CTS, XON/XOFF, ADDC® (automatic data direction control) for RS-485

**Baudrate:** 50 bps to 230.4 Kbps

### Serial Signals

**RS-232:** TxD, RxD, DTR, DSR, RTS, CTS, DCD, GND

**RS-422:** TxD+, TxD-, RxD+, RxD-, GND

**RS-485-4w:** TxD+, TxD-, RxD+, RxD-, GND

**RS-485-2w:** Data+, Data-, GND

### NMEA Interface

**Serial Standards:**

NMEA 0183v2 (NMEA 2000 available on request)

**Base Serial Standard:**

- NMEA 0183: RS-422
- NMEA 2000: CAN bus (Available on request)

**Optical Isolation Protection:** 3 kV

**Voltage Differential:** -15 V to +15 V

**Baudrate:** 4800 bps

**Data Bits:** 8

**Stop Bits:** 1, 1.5, 2

**Parity:** None

**Handshake:** None

### Digital Input

**Input Channels:** 8 dry channels, with 4 grounds

**Digital Input Levels for Dry Contacts:**

- Logic level 0: Close to GND
- Logic level 1: Open

**Connector Type:** 6-pin Phoenix-compatible 3.81 mm screw terminal block, x 2

**Isolation:** ESD protection to DNV specifications

### Relay Output

**Type:** Form A (N.O.) power relay

**Output Channels:** 8 output channels

**Contact Rating:** 2A, 30 VDC / 0.5 A, 125 VAC under resistor load

**Initial Insulation Resistance:** 1000 MΩ(min.) @500 VDC

**Mechanical Endurance:** 100,000 operations @2A, 30 VDC resistive load

**Electrical Endurance:** 100,000,000 operations

**Contact Resistance:** Max. 50 MΩ @6 V, 0.1A

**Connector Type:** 2 Euroblock 8-pin 3.81 mm screw terminals

**Isolation:** Relay isolation; ESD protection to DNV specifications

### LEDs

**System:** Storage, Power

**LAN:** 2 LEDs on each port: 100 Mbps (left) / 1000 Mbps (right)

### Physical Characteristics

**Housing:** Aluminum, sheet metal

**Weight:** 8 kg

**Dimensions:** 322 x 300 x 150 mm (12.68 x 11.81 x 5.91 in)

**Mounting:** Wall

**System Cooling:** Moxa intelligent fan

### Environmental Limits

**Operating Temperature:** -15 to 55°C (5 to 131°F)

**Storage Temperature:** -20 to 60°C (-4 to 131°F)

**Ambient Relative Humidity:** 5 to 95% (non-condensing)

**Anti-Vibration:**

- 0.7 g @ DNV 2.4 (Class A), sine wave, 2-100 Hz, 1 Oct./min., 1.5 hr per axis
- 1 G<sub>rms</sub> @ DNV 2.4, random wave, 3-100 Hz, 2.5 hr per axis
- 2.1 g @ DNV 2.4 (Class C), sine wave, 2-50 Hz, 1 Oct./min., 1.5 hr per axis

### Power Requirements

**Input Voltage:**

- DC: 24 VDC (with tolerance from 18 to 30 VDC, 2-pin terminal block)
- AC: 100 to 240 VAC

**Power Consumption:** Less than 100 W, 2.5 A @ 24 VDC

### Standards and Certifications

**Safety:** UL 60950-1, DNV 2.4, IEC 60945 (4th), IACS E10

**EMC:** EN 55022 Class B, EN 55024-4-2, EN 55024-4-3, EN 55024-4-4, FCC Part 15 Subpart B Class B

**Marine:** IEC 60945 4th, IACS E10

**Green Product:** RoHS, cRoHS, WEEE

### Reliability

**MTBF (mean time between failures):**

- Telcordia (Bellcore) Standard TR/SR: 269,934 hrs
- MIL-HDBK-217 FN2: 114,305 hrs

### Warranty

**Warranty Period:** 3 years

**Details:** See [www.moxa.com/warranty](http://www.moxa.com/warranty)

## Ordering Information

### Available Models

**MC-7130-MP:** x86-based ECDIS computer with 3rd gen. Intel® Core™ i3 CPU processor, 4 serial ports, 8 NMEA 0183 ports, 4 Gigabit Ethernet ports, 8 DIs, 8 DOs, 6 USB 2.0 ports, 2 USB 3.0 ports, 2 PCI slots, 1 PCIe x16 slot, VGA/DVI, TPM, and AC/DC power inputs

**Optional Accessories** (can be purchased separately, for AC power input)

**PWC-C13US-3B-183:** Power cord with 3-pin connector, USA plug

**PWC-C13EU-3B-183:** Power cord with 3-pin connector, Euro plug

**PWC-C13UK-3B-183:** Power cord with 3-pin connector, British plug

**PWC-C13AU-3B-183:** Power cord with 3-pin connector, Australia plug

**PWC-C13CN-3B-183:** Power cord with 3-pin connector, China plug

**Processor Options (Contact Moxa's representative for details)**

Core i3 3120ME 2.4 GHz (3M L2 Cache) (standard)

Core i7 3612QE 2.1 GHz (6M L2 Cache) (available on request)

Core i5 3610ME 2.7 GHz (3M L2 Cache) (available on request)

Celeron B810E 1.6 GHz (2M L2 Cache) (available on request)

### Package Checklist

- 1 MC-7130-MP computer
- 2 removable storage protection keys
- 8 screws for internal and removable drive trays
- Wall mounting kit
- 6 screws for wall mounting
- 1 terminal block for power input
- 4 terminal blocks for DI/DO channels
- 8 terminal blocks for NMEA 0183 ports
- Documentation and driver CD
- Quick installation guide (printed)
- Warranty card