

MDS-G4028 Series

28G-port Layer 2 full Gigabit modular managed Ethernet switches



Features and Benefits

- Multiple interface type 4-port modules for greater versatility
- Tool-free design for effortlessly adding or replacing modules without shutting down the switch
- Ultra-compact size and multiple mounting options for flexible installation
- Passive backplane to minimize maintenance efforts
- Rugged die-cast design for use in harsh environments
- Intuitive, HTML5-based web interface for a seamless experience across different platforms

Certifications



Introduction

The MDS-G4028 Series modular switches support up to 28 Gigabit ports, including 4 embedded ports, 6 interface module expansion slots, and 2 power module slots to ensure sufficient flexibility for a variety of applications. The highly compact MDS-G4000 Series is designed to meet evolving network requirements, ensuring effortless installation and maintenance, and features a hot-swappable module design that enables you to easily change or add modules without shutting down the switch or interrupting network operations.

The multiple Ethernet modules (RJ45, SFP, and PoE+) and power units (24/48 VDC, 110/220 VAC/VDC) provide even greater flexibility as well as suitability for different operating conditions, delivering an adaptive full Gigabit platform that provides the versatility and bandwidth necessary to serve as an Ethernet aggregation/edge switch. Featuring a compact design that fits in confined spaces, multiple mounting methods, and convenient tool-free module installation, the MDS-G4000 Series switches enable versatile and effortless deployment without the need for highly skilled engineers. With multiple industry certifications and a highly durable housing, the MDS-G4000 Series can reliably operate in tough and hazardous environments such as power substations, mining sites, ITS, and oil and gas applications. Support for dual power modules provides redundancy for high reliability and availability while LV and HV power module options offer additional flexibility to accommodate the power requirements of different applications.

In addition, the MDS-G4000 Series features an HTML5-based, user-friendly web interface providing a responsive, smooth user experience across different platforms and browsers.

Specifications

Ethernet Interface

Pre-installed Modules	4 embedded Gigabit ports
Module	6 slots for optional 4-port FE/GE modules
Slot Combination	See the LM-7000H module series datasheet for more information
Standards	IEEE 802.3 for 10BaseT IEEE 802.3u for 100BaseT(X) and 100BaseFX IEEE 802.3ab for 1000BaseT(X) IEEE 802.3z for 1000BaseX IEEE 802.3x for flow control IEEE 802.3ad for Port Trunk with LACP IEEE 802.1Q for VLAN Tagging IEEE 802.1D-2004 for Spanning Tree Protocol IEEE 802.1w for Rapid Spanning Tree Protocol IEEE 802.1p for Class of Service IEEE 802.1X for authentication

Ethernet Software Features

Management	IPv4/IPv6, Flow control, Back Pressure Flow Control, DHCP Server/Client, ARP, RARP, LLDP, Port Mirror, Linkup Delay, SMTP, SNMP Trap, SNMP Inform, SNMPv1/v2c/v3, RMON, TFTP, SFTP, HTTP, HTTPS, Telnet, Syslog, Private MIB
Filter	GMRP, GVRP, GARP, 802.1Q VLAN, IGMP Snooping v1/v2/v3, IGMP Querier
Redundancy Protocols	STP, RSTP, Turbo Ring v2, Turbo Chain, Ring Coupling, Dual-Homing, Link Aggregation
Security	Broadcast storm protection, Rate Limit, Trust access control, Static Port Lock, MAC Sticky, HTTPS/SSL, SSH, RADIUS, TACACS+, Login and Password Policy
Time Management	SNTP, NTP Server/Client, NTP Authentication
Protocols	IPv4/IPv6, TCP/IP, UDP, ICMP, ARP, RARP, TFTP, DNS, NTP Client, DHCP Server, DHCP Client, 802.1X, QoS, HTTPS, HTTP, Telnet, SMTP, SNMPv1/v2c/v3, RMON, Syslog
MIB	P-BRIDGE MIB, Q-BRIDGE MIB, IEEE8021-SPANNING-TREE-MIB, IEEE8021-PAE-MIB, IEEE8023-LAG-MIB, LLDP-EXT-DOT1-MIB, LLDP-EXT-DOT3-MIB, SNMPv2-MIB, RMON MIB Groups 1, 2, 3, 9

Switch Properties

MAC Table Size	16 K
Max. No. of VLANs	256
VLAN ID Range	VID 1 to 4094
IGMP Groups	1024
Priority Queues	8
Packet Buffer Size	12 Mbits

Serial Interface

Console Port	RS-232 (TxD, RxD, GND), 8-pin RJ45 (115200, n, 8, 1)
--------------	--

USB Interface

USB Connector	USB Type A (Reserved)
---------------	-----------------------

Input/Output Interface

Digital Input Channels	1 (On MGMT Module)
Digital Inputs	+13 to +30 V for state 1 -30 to +3 V for state 0 Max. input current: 8 mA
Alarm Contact Channels	3 (On MGMT, PWR1, PWR2 Module) Relay output with current carrying capacity of 2 A @ 30 VDC

Power Parameters

Input Voltage	with PWR-HV-P48 installed: 110/220 VDC, 110 VAC, 60 HZ, 220 VAC, 50 Hz, PoE: 48 VDC with PWR-LV-P48 installed: 24/48 VDC, PoE: 48 VDC with PWR-HV-NP installed: 110/220 VDC, 110 VAC, 60 HZ, 220 VAC, 50 Hz with PWR-LV-NP installed: 24/48 VDC
Operating Voltage	with PWR-HV-P48 installed: 88 to 300 VDC, 90 to 264 VAC, 47 to 63 Hz, PoE: 46 to 57 VDC

	<p>with PWR-LV-P48 installed: 18 to 72 VDC (24/48 VDC for hazardous location), PoE: 46 to 57 VDC (48 VDC for hazardous location)</p> <p>with PWR-HV-NP installed: 88 to 300 VDC, 90 to 264 VAC, 47 to 63 Hz</p> <p>with PWR-LV-NP installed: 18 to 72 VDC</p>
Input Current	<p>with PWR-HV-P48/PWR-HV-NP installed: Max. 0.11 A @ 110 VDC Max. 0.06 A @ 220 VDC Max. 0.29 A @ 110 VAC Max. 0.18 A @ 220 VAC</p> <p>with PWR-LV-P48/PWR-LV-NP installed: Max. 0.53 A @ 24 VDC Max. 0.28 A @ 48 VDC</p>
Max. PoE Power Output per Port	36 W
Total PoE Power Budget	<p>Max. 360 W (with one power supply) for total PD consumption at 48 VDC input for PoE systems</p> <p>Max. 360 W (with one power supply) for total PD consumption at 53 to 57 VDC input for PoE+ systems</p> <p>Max. 720 W (with two power supplies) for total PD consumption at 48 VDC input for PoE systems</p> <p>Max. 720 W (with two power supplies) for total PD consumption at 53 to 57 VDC input for PoE+ systems</p>
Overload Current Protection	Supported
Reverse Polarity Protection	Supported
Physical Characteristics	
IP Rating	IP40
Dimensions	218 x 115 x 163.25 mm (8.59 x 4.53 x 6.44 in)
Weight	2840 g (6.27 lb)
Installation	DIN-rail mounting, Wall mounting (with optional kit), Rack mounting (with optional kit)
Environmental Limits	
Operating Temperature	Standard Temperature: -10 to 60°C (-14 to 140°F) Wide Temperature: -40 to 75°C (-40 to 167°F)
Storage Temperature (package included)	-40 to 85°C (-40 to 185°F)
Ambient Relative Humidity	5 to 95% (non-condensing)
Standards and Certifications	
Safety	EN 62368-1, IEC 62368-1, UL 62368-1, IEC 60950-1
EMC	EN 55032/35
EMI	CISPR 32, FCC Part 15B Class A
EMS	IEC 61000-4-2 ESD: Contact: 8 kV; Air: 15 kV IEC 61000-4-3 RS: 80 MHz to 1 GHz: 20 V/m IEC 61000-4-4 EFT: Power: 4 kV; Signal: 4 kV IEC 61000-4-5 Surge: Power: 4 kV; Signal: 4 kV IEC 61000-4-6 CS: 10 V

	IEC 61000-4-8 PFMF IEC 61000-4-11
Railway	EN 50121-4
Traffic Control	NEMA TS2
Shock	IEC 60068-2-27
Freefall	IEC 60068-2-31
Vibration	IEC 60068-2-6
Hazardous Locations	ATEX, Class I Division 2
Power Substation	IEEE 1613, IEC 61850-3
MTBF	
Time	966,801 hrs
Standards	Telcordia SR332
Warranty	
Warranty Period	5 years
Details	See www.moxa.com/warranty
Package Contents	
Device	1 x MDS-G4028 Series switch
Cable	1 x RJ45-to-DB9 console cable
Installation Kit	Pre-install 2 x DIN-rail kit 2 x cap, plastic, for RJ45 port
Documentation	1 x quick installation guide 1 x product notice, Simplified Chinese 1 x product certificates of quality inspection, Simplified Chinese 1 x warranty card
Note	This product requires additional modules (sold separately) to function.

Dimensions

Unit: mm (inch)

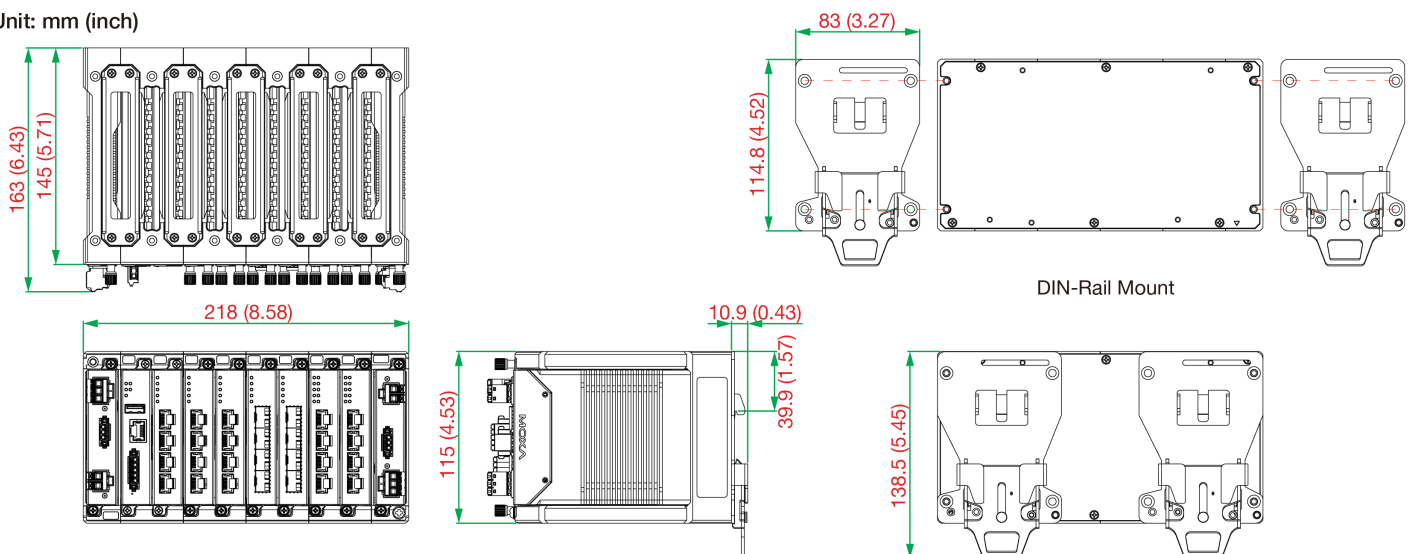

Ordering Information

Model Name	Layer	Total No. of Ports	100/1000Base SFP Slots	10/100/1000BaseT(X) Ports RJ45 Connector	PoE 10/100/1000BaseT(X) Ports RJ45 Connector	10/100BaseT(X) Ports RJ45 Connector	PoE 10/100BaseT(X) Ports RJ45 Connector	Operating Temp.
MDS-G4028	2	28	Up to 24	Up to 28	Up to 24	Up to 24	Up to 24	-10 to 60°C
MDS-G4028-T	2	28	Up to 24	Up to 28	Up to 24	Up to 24	Up to 24	-40 to 75°C

Accessories (sold separately)

LM-7000H Module Series

LM-7000H-4GTX	Gigabit Ethernet module with 4 10/100/1000BaseT(X) ports
LM-7000H-4GPoE	Gigabit Ethernet module with 4 10/100/1000BaseT(X) IEEE 802.3af/at PoE+ ports
LM-7000H-4GSFP	Gigabit Ethernet module with 4 100/1000BaseSFP slots
LM-7000H-4TX	Fast Ethernet module with 4 10/100BaseT(X) ports
LM-7000H-4PoE	Fast Ethernet module with 4 10/100BaseT(X) IEEE 802.3af/at PoE+ ports

Power Modules

PWR-LV-P48	Power supply module (24/48 VDC) with system power input, relay, PoE power input
PWR-HV-P48	Power supply module (110/220 VAC/VDC) with system power input, relay, PoE power input
PWR-LV-NP	Power supply module (24/48 VDC) with system power input, relay
PWR-HV-NP	Power supply module (110/220 VAC/VDC) with system power input, relay

Wall-Mounting Kits

WK-112-01	Wall-mounting kit, 2 plates, 8 screws
-----------	---------------------------------------

Rack-Mounting Kits

RK-3U-01	Rack-mounting kit, 4 L-shaped plates, and 2 plates with 32 screws for combining two MDS-G4028
----------	---

SFP Modules

SFP-1FEMLC-T	SFP module with 1 100Base multi-mode, LC connector for 2/4 km transmission, -40 to 85°C operating temperature
SFP-1FESLC-T	SFP module with 1 100Base single-mode with LC connector for 40 km transmission, -40 to 85°C operating temperature
SFP-1FELLC-T	SFP module with 1 100Base single-mode with LC connector for 80 km transmission, -40 to 85°C operating temperature
SFP-1G10ALC	WDM-type (BiDi) SFP module with 1 1000BaseSFP port with LC connector for 10 km transmission; TX 1310 nm, RX 1550 nm, 0 to 60°C operating temperature
SFP-1G10ALC-T	WDM-type (BiDi) SFP module with 1 1000BaseSFP port with LC connector for 10 km transmission; TX 1310 nm, RX 1550 nm, -40 to 85°C operating temperature
SFP-1G10BLC	WDM-type (BiDi) SFP module with 1 1000BaseSFP port with LC connector for 10 km transmission; TX 1550 nm, RX 1310 nm, 0 to 60°C operating temperature
SFP-1G10BLC-T	WDM-type (BiDi) SFP module with 1 1000BaseSFP port with LC connector for 10 km transmission; TX 1550 nm, RX 1310 nm, -40 to 85°C operating temperature
SFP-1G20ALC	WDM-type (BiDi) SFP module with 1 1000BaseSFP port with LC connector for 20 km transmission; TX 1310 nm, RX 1550 nm, 0 to 60°C operating temperature
SFP-1G20ALC-T	WDM-type (BiDi) SFP module with 1 1000BaseSFP port with LC connector for 20 km transmission; TX 1310 nm, RX 1550 nm, -40 to 85°C operating temperature
SFP-1G20BLC	WDM-type (BiDi) SFP module with 1 1000BaseSFP port with LC connector for 20 km transmission; TX 1550 nm, RX 1310 nm, 0 to 60°C operating temperature
SFP-1G20BLC-T	WDM-type (BiDi) SFP module with 1 1000BaseSFP port with LC connector for 20 km transmission; TX 1550 nm, RX 1310 nm, -40 to 85°C operating temperature

SFP-1G40ALC	WDM-type (BiDi) SFP module with 1 1000BaseSFP port with LC connector for 40 km transmission; TX 1310 nm, RX 1550 nm, 0 to 60°C operating temperature
SFP-1G40ALC-T	WDM-type (BiDi) SFP module with 1 1000BaseSFP port with LC connector for 40 km transmission; TX 1310 nm, RX 1550 nm, -40 to 85°C operating temperature
SFP-1G40BLC	WDM-type (BiDi) SFP module with 1 1000BaseSFP port with LC connector for 40 km transmission; TX 1550 nm, RX 1310 nm, 0 to 60°C operating temperature
SFP-1G40BLC-T	WDM-type (BiDi) SFP module with 1 1000BaseSFP port with LC connector for 40 km transmission; TX 1550 nm, RX 1310 nm, -40 to 85°C operating temperature
SFP-1GSXLC	SFP module with 1 1000BaseSX port with LC connector for 300m/550m transmission, 0 to 60°C operating temperature
SFP-1GSXLC-T	SFP module with 1 1000BaseSX port with LC connector for 300m/550m transmission, -40 to 85°C operating temperature
SFP-1GLSXLC	SFP module with 1 1000BaseLSX port with LC connector for 1km/2km transmission, 0 to 60°C operating temperature
SFP-1GLSXLC-T	SFP module with 1 1000BaseLSX port with LC connector for 1km/2km transmission, -40 to 85°C operating temperature
SFP-1GLXLC	SFP module with 1 1000BaseLX port with LC connector for 10 km transmission, 0 to 60°C operating temperature
SFP-1GLXLC-T	SFP module with 1 1000BaseLX port with LC connector for 10 km transmission, -40 to 85°C operating temperature
SFP-1GLHLC	SFP module with 1 1000BaseLH port with LC connector for 30 km transmission, 0 to 60°C operating temperature
SFP-1GLHLC-T	SFP module with 1 1000BaseLH port with LC connector for 30 km transmission, -40 to 85°C operating temperature
SFP-1GLHLC	SFP module with 1 1000BaseLHX port with LC connector for 40 km transmission, 0 to 60°C operating temperature
SFP-1GLHLC-T	SFP module with 1 1000BaseLHX port with LC connector for 40 km transmission, -40 to 85°C operating temperature
SFP-1GZXLC	SFP module with 1 1000BaseZX port with LC connector for 80 km transmission, 0 to 60°C operating temperature
SFP-1GZXLC-T	SFP module with 1 1000BaseZX port with LC connector for 80 km transmission, -40 to 85°C operating temperature
SFP-1GEZXC	SFP module with 1 1000BaseEZXC port with LC connector for 110 km transmission, 0 to 60°C operating temperature
SFP-1GEZXC-120	SFP module with 1 1000BaseEZXC port with LC connector for 120 km transmission, 0 to 60°C operating temperature
SFP-1GTXRJ45-T	SFP module with 1 1000BaseT port with RJ45 connector for 100 m transmission, -40 to 75°C operating temperature

Power Supplies

HDR-60-24	60 W/2.5 A DIN-rail 24 VDC power supply, universal 85 to 264 VAC or 120 to 370 VDC input voltage, -30 to 70°C operating temperature
NDR-120-24	120 W/5.0 A DIN-rail 24 VDC power supply, universal 90 to 264 VAC or 127 to 370 VDC input voltage, -20 to 70°C operating temperature
NDR-120-48	120 W/2.5 A DIN-rail 48 VDC power supply, universal 90 to 264 VAC or 127 to 370 VDC input voltage, -20 to 70°C operating temperature
NDR-240-48	240 W/5.0 A DIN-rail 48 VDC power supply, universal 90 to 264 VAC or 127 to 370 VDC input voltage, -20 to 70°C operating temperature

Software

MXview-50	Industrial network management software with a license for 50 nodes (by IP address)
MXview-100	Industrial network management software with a license for 100 nodes (by IP address)
MXview-250	Industrial network management software with a license for 250 nodes (by IP address)
MXview-500	Industrial network management software with a license for 500 nodes (by IP address)
MXview-1000	Industrial network management software with a license for 1000 nodes (by IP address)

MXview-2000	Industrial network management software with a license for 2000 nodes (by IP address)
MXview Upgrade-50	License expansion of MXview industrial network management software by 50 nodes (by IP address)

© Moxa Inc. All rights reserved. Updated May 18, 2022.

This document and any portion thereof may not be reproduced or used in any manner whatsoever without the express written permission of Moxa Inc. Product specifications subject to change without notice. Visit our website for the most up-to-date product information.