

Moxa TN-5916 Industrial Secure Router User Manual

Version 4.0, September 2024

www.moxa.com/products



© 2024 Moxa Inc. All rights reserved.

Moxa TN-5916 Industrial Secure Router User Manual

The software described in this manual is furnished under a license agreement and may be used only in accordance with the terms of that agreement.

Copyright Notice

© 2024 Moxa Inc. All rights reserved.

Trademarks

The MOXA logo is a registered trademark of Moxa Inc.
All other trademarks or registered marks in this manual belong to their respective manufacturers.

Disclaimer

- Information in this document is subject to change without notice and does not represent a commitment on the part of Moxa.
- Moxa provides this document as is, without warranty of any kind, either expressed or implied, including, but not limited to, its particular purpose. Moxa reserves the right to make improvements and/or changes to this manual, or to the products and/or the programs described in this manual, at any time.
- Information provided in this manual is intended to be accurate and reliable. However, Moxa assumes no responsibility for its use, or for any infringements on the rights of third parties that may result from its use.
- This product might include unintentional technical or typographical errors. Changes are periodically made to the information herein to correct such errors, and these changes are incorporated into new editions of the publication.

Technical Support Contact Information

www.moxa.com/support

Table of Contents

| | |
|---|-----------|
| 1. Introduction | 6 |
| Overview | 6 |
| Package Checklist | 6 |
| Features | 6 |
| Industrial Networking Capability..... | 6 |
| Designed for Industrial Applications..... | 6 |
| Useful Utility and Remote Configuration | 6 |
| 2. Getting Started | 8 |
| RS-232 Console Configuration (115200, None, 8, 1, VT100) | 8 |
| Using Telnet to Access the ToughNet Secure Router’s Console..... | 10 |
| Using a Web Browser to Configure the ToughNet Secure Router | 12 |
| 3. TN-5916 Series Features and Functions | 14 |
| System..... | 14 |
| System Information | 14 |
| User Account | 16 |
| Account Password Policy | 19 |
| Date and Time | 20 |
| Warning Notification | 24 |
| System File Update—by Remote TFTP | 32 |
| System File Update—by Local Import/Export | 33 |
| Back Up Media | 34 |
| Restart..... | 35 |
| Reset to Factory Default..... | 35 |
| Port | 35 |
| Port Settings..... | 35 |
| Port Status | 37 |
| Link Aggregation | 38 |
| The Port Trunking Concept | 38 |
| Port Mirror..... | 41 |
| Using Virtual LAN..... | 43 |
| The VLAN Concept..... | 43 |
| Configuring Virtual LAN | 44 |
| Multicast..... | 46 |
| The Concept of Multicast Filtering | 46 |
| IGMP Snooping | 49 |
| IGMP Snooping Settings..... | 49 |
| IGMP Table..... | 50 |
| Stream Table | 52 |
| Static Multicast MAC | 52 |
| QoS | 53 |
| ToS/DSCP Mapping..... | 55 |
| Rate Limit | 56 |
| MAC Address Table | 56 |
| Interface | 58 |
| WAN | 58 |
| LAN | 59 |
| Bridge Configuration | 61 |
| DHCP | 65 |
| DHCP Global Setting | 65 |
| Dynamic DHCP..... | 66 |
| DHCP Leases | 69 |
| IP-MAC Binding | 69 |
| IP-Port Binding | 72 |
| Configuring DHCP Relay Agent | 75 |
| SNMP | 77 |

| | |
|--|------------|
| DNS Server..... | 80 |
| DNS Global Setting..... | 81 |
| DNS Zone Setting..... | 87 |
| DNS Zone Forwarding Setting..... | 89 |
| DNS ACL Setting..... | 90 |
| DNS Security Setting..... | 92 |
| DNS Root Hints..... | 93 |
| Monitor..... | 94 |
| Statistics..... | 94 |
| Bandwidth Utilization..... | 95 |
| Packet Counter..... | 96 |
| Event Log..... | 98 |
| 4. Routing..... | 100 |
| Unicast Routing..... | 100 |
| Static Routing..... | 100 |
| Routing Information Protocol (RIP)..... | 101 |
| Open Shortest Path First (OSPF)..... | 103 |
| Routing Table..... | 110 |
| Multicast Routing..... | 111 |
| Global Setting..... | 111 |
| Static Multicast..... | 112 |
| Distance Vector Multicast Routing Protocol (DVMRP)..... | 113 |
| Protocol Independent Multicast Sparse Mode (PIM-SM)..... | 115 |
| Multicast Forwarding Table..... | 120 |
| 5. Network Redundancy..... | 121 |
| Layer 2 Redundant Protocols..... | 121 |
| Configuring RSTP..... | 121 |
| Configuring Turbo Ring V2..... | 124 |
| Layer 3 Redundant Protocols..... | 126 |
| VRRP Settings..... | 126 |
| 6. Network Address Translation..... | 129 |
| Network Address Translation (NAT)..... | 129 |
| NAT Concept..... | 129 |
| 1-to-1 NAT..... | 129 |
| N-to-1 NAT..... | 132 |
| Port Forward..... | 133 |
| 7. Firewall..... | 136 |
| Policy Concept..... | 136 |
| Policy Overview..... | 136 |
| Policy Setup..... | 137 |
| Quick Automation Profile..... | 140 |
| Layer 2 Policy Setup..... | 144 |
| Denial of Service (DoS) Defense..... | 148 |
| TRDP Packet Filter..... | 151 |
| Global Setting..... | 152 |
| Policy Setting..... | 152 |
| Firewall Degraded Mode..... | 152 |
| Firewall Degraded Mode Criteria..... | 153 |
| Entering Firewall Degraded Mode..... | 153 |
| When in Firewall Degraded Mode..... | 153 |
| Leaving Firewall Degraded Mode..... | 154 |
| Firewall Degraded Mode..... | 154 |
| Virtual Private Network (VPN)..... | 156 |
| Overview..... | 156 |
| IPsec Configuration..... | 156 |
| Global Settings..... | 156 |
| IPsec Settings..... | 157 |
| IPsec Use Case Demonstration..... | 165 |

| | |
|---|------------|
| IPsec Status | 169 |
| L2TP Server (Layer 2 Tunnel Protocol)..... | 169 |
| L2TP Configuration | 169 |
| 8. Certificate Management..... | 171 |
| Local Certificate..... | 171 |
| Local Certificate | 171 |
| Trusted CA Certificates | 172 |
| Certificate Signing Request | 172 |
| CA Server | 174 |
| 9. Security | 177 |
| User Interface Management | 177 |
| Authentication Certificate..... | 179 |
| Trusted Access | 181 |
| Radius Server | 182 |
| Global Settings | 183 |
| RADIUS Client List..... | 183 |
| Authentication User List | 184 |
| Port Access Control | 185 |
| IEEE 802.1X Setting | 186 |
| IEEE 802.1X Information | 187 |
| Authentication by Local Radius Server | 187 |
| Local User Database | 188 |
| 10. Diagnosis..... | 189 |
| Ping | 189 |
| LLDP | 189 |
| Process and Status Report | 191 |
| A. MIB Groups..... | 192 |

1. Introduction

Welcome to the Moxa TN-5916 ToughNet Secure Router Series. The ToughNet Secure Router is designed for connecting Ethernet-enabled devices with network IP security.

Overview

As the world's network and information technology becomes more mature, the trend is to use Ethernet as the major communications interface in many industrial communications and automation applications. In fact, a entirely new industry has sprung up to provide Ethernet products that comply with the requirements of demanding industrial applications.

The ToughNet TN-5916, designed for rolling stock backbone networks, is a high performance M12 router. It supports NAT, Firewall and routing functionality to facilitate the deployment of applications across networks. The TN-5916 router uses M12 and other circular connectors to ensure tight, robust connections and guarantee reliable resilience against environmental disturbances, such as vibration and shock. In addition, wide temperature models are available that operate reliably in hazardous, -40 to 75°C environments.

Package Checklist

The ToughNet Secure Routers are shipped with the following items. If any of these items are missing or damaged, please contact your customer service representative for assistance.

- 1 Moxa ToughNet Secure Router
- RJ45 to DB9 console port cable
- Protective caps for unused ports
- Quick installation guide (printed)
- CD-ROM with user's manual and Windows utility
- Warranty card

Features

Industrial Networking Capability

- Unicast and Multicast routing
- Network Redundancy (Layer 2 and Layer 3)
- Network address translation (N-to-1, 1-to-1, and port forwarding)
- Firewall and Denial of Service (DoS) Defense

Designed for Industrial Applications

- Bypass relay ensures non-stop data communication in the event the router stops working due to a power failure
- EN 50155/50121-3-2 compliant. See specs for details about compliance with specific parts of these standards
- -40 to 75°C operating temperature (T models)
- Dual 24 to 110 VDC power inputs
- IP54, rugged high-strength metal case
- DIN rail or panel mounting ability

Useful Utility and Remote Configuration

- Configurable using a Web browser and Telnet/Serial console

- Send ping commands to identify network segment integrity

2. Getting Started

This chapter explains how to access the ToughNet Secure Router for the first time. There are three ways to access the router: (1) serial console, (2) Telnet console, and (3) web browser. The serial console connection method, which requires using a short serial cable to connect the ToughNet Secure Router to a PC's COM port, can be used if you do not know the ToughNet Secure Router's IP address. The Telnet console and web browser connection methods can be used to access the ToughNet Secure Router over an Ethernet LAN, or over the Internet. A web browser can be used to perform all monitoring and administration functions, but the serial console and Telnet console only provide basic functions.

RS-232 Console Configuration (115200, None, 8, 1, VT100)



NOTE

Connection Caution!

We strongly suggest that you do NOT use more than one connection method at the same time. Following this advice will allow you to maintain better control over the configuration of your ToughNet Secure Router



NOTE

We recommend using Moxa PComm Terminal Emulator, which can be downloaded free of charge from Moxa's website.

Before running PComm Terminal Emulator, use an RJ45 to DB9-F (or RJ45 to DB25-F) cable to connect the ToughNet Secure Router's RS-232 console port to your PC's COM port (generally COM1 or COM2, depending on how your system is set up).

After installing PComm Terminal Emulator, perform the following steps to access the RS-232 console utility.

1. From the Windows desktop, click **Start > Programs > PCommLite1.3 > Terminal Emulator**.

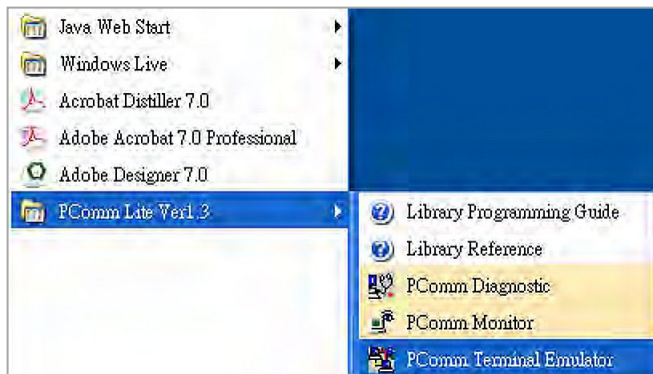

2. Select **Open** in the Port Manager menu to open a new connection.

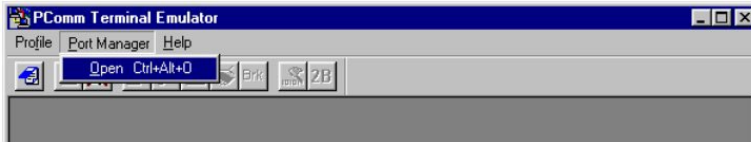

3. The **Communication Parameter** page of the **Property** window will appear. Select the appropriate COM port from the **Ports** drop-down list, 115200 for Baud Rate, 8 for Data Bits, None for Parity, and 1 for Stop Bits.

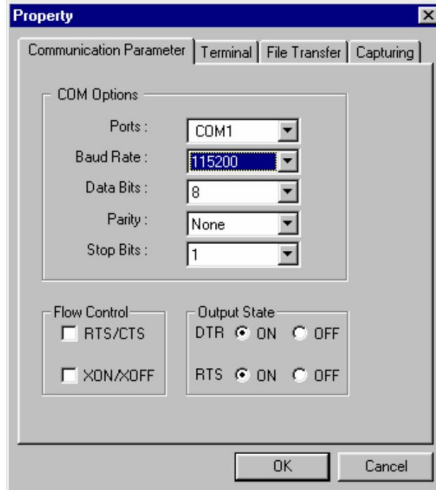

4. Click the **Terminal** tab, select VT100 for Terminal Type, and then click **OK** to continue.
5. The **Console** login screen will appear. Use the keyboard to enter the login account (**admin** or **user**), and then press **Enter** to jump to the **Password** field. Enter the console Password (the same as the Web Browser password; leave the Password field blank if a console password has not been set), and then press **Enter**.

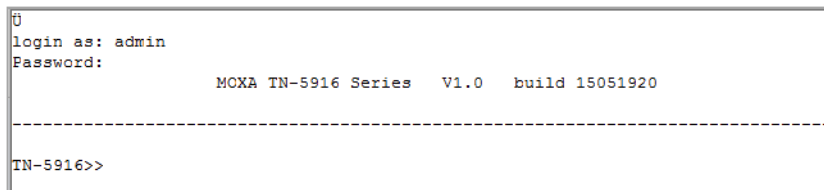

NOTE

The default password is moxa. For greater security, please change the default password after the first log in.

6. Enter a question mark (?) to display the command list in the console.

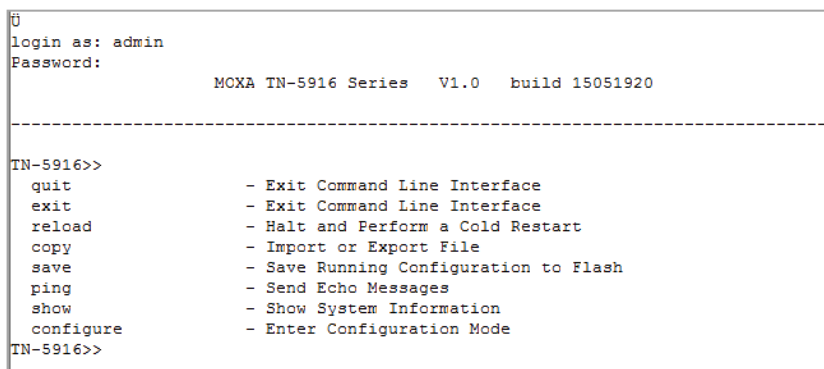

The following table lists commands that can be used when the ToughNet Secure Router is in console (serial or Telnet) mode:

Login by Admin Account

| Command | Description |
|-----------|-------------------------------------|
| quit | Exit Command Line Interface |
| exit | Exit Command Line Interface |
| reload | Halt and Perform a Cold Restart |
| terminal | Configure Terminal Page Length |
| copy | Import or Export File |
| save | Save Running Configuration to Flash |
| ping | Send Echo Messages |
| clear | Clear Information |
| show | Show System Information |
| configure | Enter Configuration Mode |

Using Telnet to Access the ToughNet Secure Router's Console

You may use Telnet to access the ToughNet Secure Router's console utility over a network. To access the TN's functions over the network (by either Telnet or a web browser) from a PC host that is connected to the same LAN as the ToughNet Secure Router, you need to make sure that the PC host and the ToughNet Secure Router are on the same logical subnet. To do this, check your PC host's IP address and subnet mask. By default, the LAN IP address is 192.168.127.254 and the Industrial subnet mask is 255.255.255.0 (for a Class C subnet). If you do not change these values, and your PC host's subnet mask is 255.255.0.0, then its IP address must have the form 192.168.xxx.xxx. On the other hand, if your PC host's subnet mask is 255.255.255.0, then its IP address must have the form, 192.168.127.xxx.



NOTE

To use the ToughNet Secure Router's management and monitoring functions from a PC host connected to the same LAN as the ToughNet Secure Router, you must make sure that the PC host and the ToughNet Secure Router are connected to the same logical subnet.

**NOTE**

Before accessing the console utility via Telnet, first connect the ToughNet Secure Router's RJ45 Ethernet LAN ports to your Ethernet LAN, or directly to your PC's Ethernet card (NIC). You can use either a straight-through or cross-over Ethernet cable.

**NOTE**

The ToughNet Secure Router's default LAN IP address is 192.168.127.254.

Perform the following steps to access the console utility via Telnet.

1. Click **Start > Run**, and then telnet to the ToughNet Secure Router's IP address from the Windows Run window. (You may also issue the Telnet command from the MS-DOS prompt.)

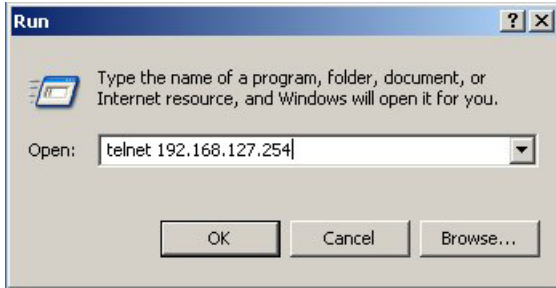

2. Refer to instructions 6 and 7 in the **RS-232 Console Configuration (115200, None, 8, 1, VT100)** section on page 6.

Using a Web Browser to Configure the ToughNet Secure Router

The ToughNet Secure Router's web browser interface provides a convenient way to modify the router's configuration and access the built-in monitoring and network administration functions. The recommended web browser is Microsoft Internet Explorer 6.0 with JVM (Java Virtual Machine) installed.



NOTE

To use the ToughNet Secure Router's management and monitoring functions from a PC host connected to the same LAN as the ToughNet Secure Router, you must make sure that the PC host and the ToughNet Secure Router are connected to the same logical subnet.



NOTE

Before accessing the ToughNet Secure Router's web browser, first connect the ToughNet Secure Router's M12 Ethernet LAN ports to your Ethernet LAN, or directly to your PC's Ethernet card (NIC). You can use either a straight-through or cross-over Ethernet cable.



NOTE

The ToughNet Secure Router's default LAN IP address is 192.168.127.254.

Perform the following steps to access the ToughNet Secure Router's web browser interface.

1. Start Internet Explorer and type the ToughNet Secure Router's LAN IP address in the Address field. Press Enter to establish the connection.



2. The web login page will open. Select the login account (Admin or User) and enter the **Password** (the same as the Console password), and then click Login to continue. Leave the **Password** field blank if a password has not been set.

TN-5916

Username :

Password :

Login



NOTE

The default password is moxa. For greater security, please change the default password after the first log in.

You may need to wait a few moments for the web page to be downloaded to your computer. Use the menu tree on the left side of the window to open the function pages to access each of the router's functions.

MOXA® ToughNet Switch TN-5916-T Series www.moxa.com

Model: TN-5916-T Serial No.: 05515 MAC Addr.: 00-90-e8-22-05-15 PWR1 ■ MSTR ■ FAULT ■
Name: NAT Router Location: Device Location Firmware Ver.: V1.2.24 build 18122715 PWR2 ■ CPLR ■

Overview

Update

| Interface Status | | More... | | Recent 10 Event Log | | More... | |
|------------------|------|---------|------------|--------------------------------------|--------------------|---------|--|
| Interface | Mode | PPPoE | Status | Event | Time | | |
| WAN | WAN | N/A | Disconnect | Admin Auth Ok | 2019/3/26,22:24:24 | | |
| LAN1 | LAN | N/A | Connect | Port 6 Link Off | 2019/3/26,23:29:49 | | |
| LAN2 | LAN | N/A | Disconnect | Power 1 Power Transition (Off -> On) | 2019/3/27,19:36:17 | | |
| LAN3 | LAN | N/A | Disconnect | Power 2 Power Transition (Off -> On) | 2019/3/27,19:36:17 | | |
| | | | | Cold Start | 2019/3/27,19:36:42 | | |
| | | | | Power 1 Power Transition (Off -> On) | 2019/3/28,0:25:35 | | |
| | | | | Power 2 Power Transition (Off -> On) | 2019/3/28,0:25:35 | | |
| | | | | Cold Start | 2019/3/28,0:26:0 | | |
| | | | | Port 6 Link On | 2019/3/28,7:18:37 | | |
| | | | | Admin Auth Ok | 2019/3/28,7:18:53 | | |

goahead WEB SERVER

3. TN-5916 Series Features and Functions

The web browser is the most user-friendly way to configure the ToughNet Secure Router, since you can both monitor the ToughNet Secure Router and use administration functions from the web browser. An RS-232 or Telnet console connection only provides basic functions. In this chapter, we use the web browser to introduce the ToughNet Secure Router's configuration and monitoring functions.

System

The **System** section includes the most common settings required by administrators to maintain and control a Moxa switch.

System Information

Defining System Information items to make different switches easier to identify that are connected to your network.

System Identification

| | |
|-------------------------|--|
| Router Name | <input type="text" value="NAT Router"/> |
| Router Location | <input type="text" value="Device Location"/> |
| Router Description | <input type="text"/> |
| Maintainer Contact Info | <input type="text"/> |

Web login message

Login authentication failure message

System Usage

| | |
|------------------------------|----------|
| CPU Usage (Every 5 seconds) | 9.48 % |
| CPU Usage (Every 30 seconds) | 11.74 % |
| CPU Usage (Every 5 minutes) | 12.82 % |
| Free Memory | 68644 kB |

Router Name

| Setting | Description | Factory Default |
|--------------------|--|-----------------|
| Max. 30 characters | This option is useful for differentiating between the roles or applications of different units. Example: Factory Switch 1. | NAT Router |

Router Location

| Setting | Description | Factory Default |
|--------------------|---|-----------------|
| Max. 80 characters | This option is useful for differentiating between the locations of different units. Example: production line 1. | Device Location |

Router Description

| Setting | Description | Factory Default |
|--------------------|--|-----------------|
| Max. 30 characters | This option is useful for recording a more detailed description of the unit. | None |

Maintainer Contact Info

| Setting | Description | Factory Default |
|--------------------|--|-----------------|
| Max. 30 characters | This option is useful for providing information about who is responsible for maintaining this unit and how to contact this person. | None |

Web Login Message

| Setting | Description | Factory Default |
|---------------------|---|-----------------|
| Max. 512 characters | This option is useful for providing a welcome message when a user has logged in successfully. | None |

Login Authentication Failure Message

| Setting | Description | Factory Default |
|---------------------|---|-----------------|
| Max. 512 characters | This option is useful for providing a message when a user has failed to log in. | None |

System Usage

| Setting | Description | Factory Default |
|-------------|--|-----------------|
| CPU usage | The CPU usage over different time periods (5 sec, 30 sec, or 5 min). | None |
| Free memory | The available memory size of the system. | None |

User Account

The Moxa ToughNet Secure Router supports the management of accounts, including establishing, activating, modifying, disabling and removing accounts. There are two levels of configuration access, admin and user. The account belongs to **admin** privilege has read/write access of all configuration parameters, while the account belongs to **user** authority has read access to view the configuration only.



NOTE

1. In consideration of higher security level, strongly suggest to change the default password after first log in.
2. The user with 'admin' account name can't be deleted and disabled by default.

User Account

Active

Authority Admin ▾

User Name

Password

Confirm Password

Create Apply

| Active | User Name | Authority | |
|-------------------------------------|-----------|-----------|---|
| <input checked="" type="checkbox"/> | admin | Admin | Delete |
| <input checked="" type="checkbox"/> | user | User | Delete |

Active

| Setting | Description | Factory Default |
|-----------|---|-----------------|
| Checked | The Moxa switch can be accessed by the activated user name | Enabled |
| Unchecked | The Moxa switch can't be accessed by the non-activated user | |

Authority

| Setting | Description | Factory Default |
|----------------|---|------------------------|
| admin | The account has read/write access of all configuration parameters. | admin |
| user | The account can only read configuration but without any modification. | |

Create New Account

Input the user name, password and assign the authority to the new account. Once apply the new setting, the new account will be shown under the Account List table.

| Setting | Description | Factory Default |
|--------------------------------------|---|------------------------|
| User Name (Max. of 30 characters) | User Name | None |
| Password | Password for the user account. Minimum requirement is 4 characters, maximum of 16 characters | None |

Modify Existing Account

Select the existing account from the Account List table. Modify the details accordingly then apply the setting to save the configuration.

User Account

Active

Authority

User Name

Old Password

New Password

Confirm Password

| Active | User Name | Authority | |
|-------------------------------------|-----------|-----------|---------------------------------------|
| <input checked="" type="checkbox"/> | admin | Admin | <input type="button" value="Delete"/> |
| <input checked="" type="checkbox"/> | user | User | <input type="button" value="Delete"/> |

Delete Existing Account

Select the existing account from the Account List table. Press delete button to delete the account.

User Account

Active

Authority

User Name

Old Password

New Password

Confirm Password

| Active | User Name | Authority | |
|-------------------------------------|-----------|-----------|---------------------------------------|
| <input checked="" type="checkbox"/> | admin | Admin | <input type="button" value="Delete"/> |
| <input checked="" type="checkbox"/> | user | User | <input type="button" value="Delete"/> |
| <input checked="" type="checkbox"/> | testuser1 | Admin | <input type="button" value="Delete"/> |

Account Password Policy

To prevent hackers from obtaining switch account passwords, Moxa switches allow users to configure a password policy and lock the account in the event that the wrong password is entered too many times. The account password policy can require passwords to be of a minimum length and complexity with a strength check. If Account Login Failure Lockout is enabled, you can configure the Retry Failure Threshold and Lockout Time parameters to determine the number of failed attempts before the account is locked and the duration of the lockout.

Account Password and Login Management

Account Password Policy

Minimum Length (4~16)

Enable password complexity strength check

- At least one digit (0~9)
- Mixed upper and lower case letters (A~Z, a~z)
- At least one special character (~!@#\$\$%^&*~_!;:,.<>[]{}())

Account Login Failure Lockout

Enable

Retry Failure Threshold (1~10)

Lockout Time (min) (1~60)

Account Password Policy

| Setting | Description | Factory Default |
|--------------------------------|---|-----------------|
| User-specified password length | Specify the minimum and maximum character length of user passwords. | 4 |
| Password complexity check | Enable additional password complexity requirements for passwords. | None |

Account Login Failure Lockout

| Setting | Description | Factory Default |
|-----------------|--|-----------------|
| Enable/Disable | Enable account lockout to prevent a user from logging in for a specified duration if the wrong password is entered too many times. | 4 |
| Retry threshold | Specify the maximum number of login retries before the account is locked out. | 5 |

| Setting | Description | Factory Default |
|------------------|---|-----------------|
| Lockout duration | Specify the lockout duration (in minutes) during which a locked out account will be unable to log in. | 5 |

Date and Time

The Moxa ToughNet Secure Router has a time calibration function based on information from an NTP server or user specified time and date. Functions such as automatic warning emails can therefore include time and date stamp.



NOTE

The Moxa ToughNet Secure Router does not have a real time clock. The user must update the Current Time and Current Date to set the initial time for the Moxa switch after each reboot, especially when there is no NTP server on the LAN or Internet connection.

Date and Time

System Up Time: 0d5h38m52s
 Current Time: 2019/03/12 01:59:16
 Clock Source: Local NTP SNTP

Time Settings

Manual Time Settings
 Date(YYYY/MM/DD): / / (ex: 2002/11/13)
 Time(HH:MM:SS): : : (ex: 04:00:04)
 Sync with Local Device: 2019/03/26 15:11:15

NTP/SNTP Server Settings

NTP/SNTP Server: Enable

TimeZone Settings

Time Zone: (GMT)Greenwich Mean Time: Dublin, Edinburgh, Lisbon, London ▼

Daylight Saving Time

| | Month | Week | Day | Hour | Min |
|------------|-------|------|------|------|------|
| Start Date | -- ▼ | -- ▼ | -- ▼ | -- ▼ | -- ▼ |
| End Date | -- ▼ | -- ▼ | -- ▼ | -- ▼ | -- ▼ |
| Offset(hr) | 0 ▼ | | | | |

System Up Time

Indicates how long the Moxa ToughNet Secure Router remained up since the last cold start.

Current Time

Indicate current time using the yyyy-mm-dd format.

Clock Source

| Setting | Description | Factory Default |
|---------|--|-----------------|
| Local | Configure clock source from local time | Local |
| NTP | Configure clock source from NTP | |
| SNTP | Configure clock source from SNTP | |

The ToughNet Secure Router supports Local Clock Source, and user can set up time manually or synchronize with local devices.

| | |
|---|---|
| System Up Time | 0d5h38m52s |
| Current Time | 2019/03/12 01:59:16 |
| Clock Source | <input checked="" type="radio"/> Local <input type="radio"/> NTP <input type="radio"/> SNTP |
| Time Settings | |
| <input checked="" type="radio"/> Manual Time Settings | |
| Date(YYYY/MM/DD) | <input type="text"/> / <input type="text"/> / <input type="text"/> (ex: 2002/11/13) |
| Time(HH:MM:SS) | <input type="text"/> : <input type="text"/> : <input type="text"/> (ex: 04:00:04) |
| <input type="radio"/> Sync with Local Device | 2019/03/26 15:15:14 |

Time Setting

| Setting | Description | Factory Default |
|------------------------|--|----------------------------------|
| Manual Time Setting | Manual setup time with the format: Date (YYYY/MM/DD) Time (HH:MM:SS) | None |
| Sync with Local Device | Synchronize time with local device | Current time in the local device |

The ToughNet Secure Router supports NTP/SNTP client function for time synchronization. Two NTP/SNTP servers can be set.

| | |
|----------------------------|---|
| System Up Time | 0d5h38m52s |
| Current Time | 2019/03/12 01:59:16 |
| Clock Source | <input type="radio"/> Local <input checked="" type="radio"/> NTP <input type="radio"/> SNTP |
| NTP Client Settings | |
| 1st Time Server | <input type="text"/> |
| 2nd Time Server | <input type="text"/> |

| | |
|-----------------------------|---|
| System Up Time | 0d5h38m52s |
| Current Time | 2019/03/12 01:59:16 |
| Clock Source | <input type="radio"/> Local <input type="radio"/> NTP <input checked="" type="radio"/> SNTP |
| SNTP Client Settings | |
| 1st Time Server | <input type="text"/> |
| 2nd Time Server | <input type="text"/> |

NTP/SNTP Client Settings

| Setting | Description | Factory Default |
|---|---|-----------------|
| IP address or name of time server | The IP or domain address (e.g. 192.168.1.1, time.stdtime.gov.tw, or time.nist.gov) | None |
| IP address or name of secondary time server | The ToughNet Secure Router will try to locate the secondary NTP/SNTP server if the first server fails to connect. | |

The ToughNet Secure Router supports NTP/SNTP Server, Time Zone Setting, and Daylight Saving functions.

NTP/SNTP Server Settings

NTP/SNTP Server Enable

TimeZone Settings

Time Zone

Daylight Saving Time

| | Month | Week | Day | Hour | Min |
|------------|-------|------|------|------|------|
| Start Date | -- ▾ | -- ▾ | -- ▾ | -- ▾ | -- ▾ |
| End Date | -- ▾ | -- ▾ | -- ▾ | -- ▾ | -- ▾ |
| Offset(hr) | 0 ▾ | | | | |

NTP/SNTP Syslog Option

Enable Syslog

NTP/SNTP Server

| Setting | Description | Factory Default |
|----------------|--|-----------------|
| Enable/Disable | Enable NTP/SNTP server functionality for clients | Disable |

Time Zone

| Setting | Description | Factory Default |
|----------------|---|---------------------------|
| Time zone | Specifies the time zone, which is used to determine the local time offset from GMT (Greenwich Mean Time). | GMT (Greenwich Mean Time) |



NOTE

Changing the time zone will automatically correct the current time. Be sure to set the time zone before setting the time.

The Daylight Saving Time settings are used to automatically set the ToughNet Secure Router's time according to national standards.

Start Date

| Setting | Description | Factory Default |
|---------------------|--|-----------------|
| User-specified date | Specifies the date that Daylight Saving Time begins. | None |

End Date

| Setting | Description | Factory Default |
|---------------------|--|-----------------|
| User-specified date | Specifies the date that Daylight Saving Time ends. | None |

Offset

| Setting | Description | Factory Default |
|---------------------|--|-----------------|
| User-specified hour | Specifies the number of hours that the time should be set forward during Daylight Saving Time. | None |

NTP/SNTP Syslog Option

| Setting | Description | Factory Default |
|---------|--|-----------------|
| Enable | Send NTP/SNTP log message to syslog server | Disable |

Warning Notification

Since industrial Ethernet devices are often located at the endpoints of a system, these devices will not always know what is happening elsewhere on the network. This means that an ToughNet Secure Router that connects to these devices must provide system maintainers with real-time alarm messages. Even when control engineers are out of the control room for an extended period of time, they can still be informed of the status of devices almost instantaneously when exceptions occur. The Moxa ToughNet Secure Router supports different approaches to warn engineers automatically, such as email, trap, syslog and relay output. It also supports one digital input to integrate sensors into your system to automate alarms by email and relay output.

System Event Settings

System Events are related to the overall function of the switch. Each event can be activated independently with different warning approaches. Administrator also can decide the severity of each system event.

System Event Settings

| Enable | Event | Action | | | | | Severity |
|--------------------------|-----------------------------|--------------------------|--------------------------|--------------------------|--------------------------|--------------------------|----------|
| | | SNMP-Trap | E-Mail | Syslog | Relay 1 | Relay 2 | |
| <input type="checkbox"/> | Cold Start | <input type="checkbox"/> | <input type="checkbox"/> | <input type="checkbox"/> | | | EMERG ▼ |
| <input type="checkbox"/> | Warm Start | <input type="checkbox"/> | <input type="checkbox"/> | <input type="checkbox"/> | | | EMERG ▼ |
| <input type="checkbox"/> | Power 1 Transition (On~Off) | <input type="checkbox"/> | <input type="checkbox"/> | <input type="checkbox"/> | <input type="checkbox"/> | <input type="checkbox"/> | EMERG ▼ |
| <input type="checkbox"/> | Power 2 Transition (On~Off) | <input type="checkbox"/> | <input type="checkbox"/> | <input type="checkbox"/> | <input type="checkbox"/> | <input type="checkbox"/> | EMERG ▼ |
| <input type="checkbox"/> | Power 1 Transition (Off~On) | <input type="checkbox"/> | <input type="checkbox"/> | <input type="checkbox"/> | | | EMERG ▼ |
| <input type="checkbox"/> | Power 2 Transition (Off~On) | <input type="checkbox"/> | <input type="checkbox"/> | <input type="checkbox"/> | | | EMERG ▼ |
| <input type="checkbox"/> | Config. Change | <input type="checkbox"/> | <input type="checkbox"/> | <input type="checkbox"/> | | | EMERG ▼ |
| <input type="checkbox"/> | Auth. Failure | <input type="checkbox"/> | <input type="checkbox"/> | <input type="checkbox"/> | | | EMERG ▼ |

| Enable | Event | Threshold (%) | Duration (Sec) | Action | | | Severity |
|--------------------------|-----------------|---------------------------------|---------------------------------|--------------------------|--------------------------|--------------------------|----------|
| | | | | E-Mail | Syslog | Status Report | |
| <input type="checkbox"/> | CPU Usage Alarm | <input type="text" value="80"/> | <input type="text" value="10"/> | <input type="checkbox"/> | <input type="checkbox"/> | <input type="checkbox"/> | WARN ▼ |

Apply

| System Events | Description |
|---------------------------|---|
| Cold Start | Power is cut off and then reconnected. |
| Warm Start | Moxa ToughNet Secure Router is rebooted, such as when network parameters are changed (IP address, subnet mask, etc.). |
| Power Transition (On→Off) | Moxa ToughNet Secure Router is powered down. |
| Power Transition (Off→On) | Moxa ToughNet Secure Router is powered up. |
| Configuration Change | Any configuration item has been changed. |
| Authentication Failure | An incorrect password was entered. |
| CPU Usage Alarm | CPU utilization exceeds the designated threshold for a specified period of time. |

There are four response actions available on the TN-5900 series when events are triggered.

| Action | Description |
|--------|---|
| Trap | The ToughNet Secure Router will send notification to the trap server when event is triggered. |

| Action | Description |
|--------|--|
| E-Mail | The ToughNet Secure Router will send notification to the email server defined in the Email Setting. |
| Syslog | The ToughNet Secure Router will record a syslog to syslog server defined in Syslog Server Setting. |
| Relay | The ToughNet Secure Router supports digital inputs to integrate sensors. When event is triggered, the device will automate alarms by relay output. |

Severity

| Severity | Description |
|-------------|----------------------------------|
| Emergency | System is unusable |
| Alert | Action must be taken immediately |
| Critical | Critical conditions |
| Error | Error conditions |
| Warning | Warning conditions |
| Notice | Normal but significant condition |
| Information | Informational messages |
| Debug | Debug-level messages |

CPU Usage Alarm

The ToughNet Secure Router will record and send event logs when CPU usage exceeds the defined threshold and duration.

| Enable | Event | Threshold (%) | Duration (Sec) | Action | | | Severity |
|--------------------------|-----------------|---------------------------------|---------------------------------|--------------------------|--------------------------|--------------------------|---------------------------------------|
| | | | | E-Mail | Syslog | Status Report | |
| <input type="checkbox"/> | CPU Usage Alarm | <input type="text" value="80"/> | <input type="text" value="10"/> | <input type="checkbox"/> | <input type="checkbox"/> | <input type="checkbox"/> | WARN <input type="button" value="v"/> |

| Setting | Description | Factory Default |
|-----------|--|-----------------|
| Threshold | Specifies the threshold percentage that triggers the CPU usage alarm. Valid Range: 60 to 90 | 80 |
| Duration | Specifies the number of seconds the CPU usage exceeds threshold before triggering the CPU Usage alarm Valid Range: 10 to 60 | 10 |
| Action | The ToughNet Secure Router will send notifications to the email server, Syslog, and status report when the corresponding actions are checked | None |
| Severity | Specifies severity of event notification when CPU Usage alarm is triggered | WARN/Warning |

Port Event Settings

Port Events are related to the activity of a specific port.

| Port Event Settings | | | | | | | | | |
|-----------------------------------|------|----------------------------------|-----------------------------------|------------------------------------|---------------------------------|---------------------------------|----------------------------------|----------------------------------|----------|
| Apply <input type="checkbox"/> | Port | <input type="checkbox"/> Link-On | <input type="checkbox"/> Link-Off | Action | | | | | Severity |
| | | | | <input type="checkbox"/> SNMP-Trap | <input type="checkbox"/> E-Mail | <input type="checkbox"/> Syslog | <input type="checkbox"/> Relay 1 | <input type="checkbox"/> Relay 2 | |
| <input type="checkbox"/> | 1 | <input type="checkbox"/> | <input type="checkbox"/> | <input type="checkbox"/> | <input type="checkbox"/> | <input type="checkbox"/> | <input type="checkbox"/> | <input type="checkbox"/> | EMERG ▾ |
| <input type="checkbox"/> | 2 | <input type="checkbox"/> | <input type="checkbox"/> | <input type="checkbox"/> | <input type="checkbox"/> | <input type="checkbox"/> | <input type="checkbox"/> | <input type="checkbox"/> | EMERG ▾ |
| <input type="checkbox"/> | 3 | <input type="checkbox"/> | <input type="checkbox"/> | <input type="checkbox"/> | <input type="checkbox"/> | <input type="checkbox"/> | <input type="checkbox"/> | <input type="checkbox"/> | EMERG ▾ |
| <input type="checkbox"/> | 4 | <input type="checkbox"/> | <input type="checkbox"/> | <input type="checkbox"/> | <input type="checkbox"/> | <input type="checkbox"/> | <input type="checkbox"/> | <input type="checkbox"/> | EMERG ▾ |
| <input type="checkbox"/> | 5 | <input type="checkbox"/> | <input type="checkbox"/> | <input type="checkbox"/> | <input type="checkbox"/> | <input type="checkbox"/> | <input type="checkbox"/> | <input type="checkbox"/> | EMERG ▾ |
| <input type="checkbox"/> | 6 | <input type="checkbox"/> | <input type="checkbox"/> | <input type="checkbox"/> | <input type="checkbox"/> | <input type="checkbox"/> | <input type="checkbox"/> | <input type="checkbox"/> | EMERG ▾ |
| <input type="checkbox"/> | 7 | <input type="checkbox"/> | <input type="checkbox"/> | <input type="checkbox"/> | <input type="checkbox"/> | <input type="checkbox"/> | <input type="checkbox"/> | <input type="checkbox"/> | EMERG ▾ |
| <input type="checkbox"/> | 8 | <input type="checkbox"/> | <input type="checkbox"/> | <input type="checkbox"/> | <input type="checkbox"/> | <input type="checkbox"/> | <input type="checkbox"/> | <input type="checkbox"/> | EMERG ▾ |
| <input type="checkbox"/> | 9 | <input type="checkbox"/> | <input type="checkbox"/> | <input type="checkbox"/> | <input type="checkbox"/> | <input type="checkbox"/> | <input type="checkbox"/> | <input type="checkbox"/> | EMERG ▾ |
| <input type="checkbox"/> | 10 | <input type="checkbox"/> | <input type="checkbox"/> | <input type="checkbox"/> | <input type="checkbox"/> | <input type="checkbox"/> | <input type="checkbox"/> | <input type="checkbox"/> | EMERG ▾ |
| <input type="checkbox"/> | 11 | <input type="checkbox"/> | <input type="checkbox"/> | <input type="checkbox"/> | <input type="checkbox"/> | <input type="checkbox"/> | <input type="checkbox"/> | <input type="checkbox"/> | EMERG ▾ |
| <input type="checkbox"/> | 12 | <input type="checkbox"/> | <input type="checkbox"/> | <input type="checkbox"/> | <input type="checkbox"/> | <input type="checkbox"/> | <input type="checkbox"/> | <input type="checkbox"/> | EMERG ▾ |
| <input type="checkbox"/> | 13 | <input type="checkbox"/> | <input type="checkbox"/> | <input type="checkbox"/> | <input type="checkbox"/> | <input type="checkbox"/> | <input type="checkbox"/> | <input type="checkbox"/> | EMERG ▾ |
| <input type="checkbox"/> | 14 | <input type="checkbox"/> | <input type="checkbox"/> | <input type="checkbox"/> | <input type="checkbox"/> | <input type="checkbox"/> | <input type="checkbox"/> | <input type="checkbox"/> | EMERG ▾ |
| <input type="checkbox"/> | 15 | <input type="checkbox"/> | <input type="checkbox"/> | <input type="checkbox"/> | <input type="checkbox"/> | <input type="checkbox"/> | <input type="checkbox"/> | <input type="checkbox"/> | EMERG ▾ |
| <input type="checkbox"/> | 16 | <input type="checkbox"/> | <input type="checkbox"/> | <input type="checkbox"/> | <input type="checkbox"/> | <input type="checkbox"/> | <input type="checkbox"/> | <input type="checkbox"/> | EMERG ▾ |

| Port Events | Warning e-mail is sent when... |
|-------------|--|
| Link-ON | The port is connected to another device. |
| Link-OFF | The port is disconnected (e.g., the cable is pulled out, or the opposing device shuts down). |

Port Usage Alarm

The ToughNet Secure Router will record and send event log when selected ports receiving or transmitting data exceeding the defined threshold for a specified duration.

| Apply <input type="checkbox"/> | Port | Traffic-Overload | | | | | | Action | | | Severity |
|-----------------------------------|------|-----------------------------|------------------|-------------------|-----------------------------|------------------|-------------------|---------------------------------|---------------------------------|--|----------|
| | | <input type="checkbox"/> Tx | Tx Threshold (%) | Tx Duration (Sec) | <input type="checkbox"/> Rx | Rx Threshold (%) | Rx Duration (Sec) | <input type="checkbox"/> E-Mail | <input type="checkbox"/> Syslog | <input type="checkbox"/> Status Report | |
| <input type="checkbox"/> | 1 | <input type="checkbox"/> | 50 | 10 | <input type="checkbox"/> | 50 | 10 | <input type="checkbox"/> | <input type="checkbox"/> | <input type="checkbox"/> | WARN |
| <input type="checkbox"/> | 2 | <input type="checkbox"/> | 50 | 10 | <input type="checkbox"/> | 50 | 10 | <input type="checkbox"/> | <input type="checkbox"/> | <input type="checkbox"/> | WARN |
| <input type="checkbox"/> | 3 | <input type="checkbox"/> | 50 | 10 | <input type="checkbox"/> | 50 | 10 | <input type="checkbox"/> | <input type="checkbox"/> | <input type="checkbox"/> | WARN |
| <input type="checkbox"/> | 4 | <input type="checkbox"/> | 50 | 10 | <input type="checkbox"/> | 50 | 10 | <input type="checkbox"/> | <input type="checkbox"/> | <input type="checkbox"/> | WARN |
| <input type="checkbox"/> | 5 | <input type="checkbox"/> | 50 | 10 | <input type="checkbox"/> | 50 | 10 | <input type="checkbox"/> | <input type="checkbox"/> | <input type="checkbox"/> | WARN |
| <input type="checkbox"/> | 6 | <input type="checkbox"/> | 50 | 10 | <input type="checkbox"/> | 50 | 10 | <input type="checkbox"/> | <input type="checkbox"/> | <input type="checkbox"/> | WARN |
| <input type="checkbox"/> | 7 | <input type="checkbox"/> | 50 | 10 | <input type="checkbox"/> | 50 | 10 | <input type="checkbox"/> | <input type="checkbox"/> | <input type="checkbox"/> | WARN |
| <input type="checkbox"/> | 8 | <input type="checkbox"/> | 50 | 10 | <input type="checkbox"/> | 50 | 10 | <input type="checkbox"/> | <input type="checkbox"/> | <input type="checkbox"/> | WARN |
| <input type="checkbox"/> | 9 | <input type="checkbox"/> | 50 | 10 | <input type="checkbox"/> | 50 | 10 | <input type="checkbox"/> | <input type="checkbox"/> | <input type="checkbox"/> | WARN |
| <input type="checkbox"/> | 10 | <input type="checkbox"/> | 50 | 10 | <input type="checkbox"/> | 50 | 10 | <input type="checkbox"/> | <input type="checkbox"/> | <input type="checkbox"/> | WARN |
| <input type="checkbox"/> | 11 | <input type="checkbox"/> | 50 | 10 | <input type="checkbox"/> | 50 | 10 | <input type="checkbox"/> | <input type="checkbox"/> | <input type="checkbox"/> | WARN |
| <input type="checkbox"/> | 12 | <input type="checkbox"/> | 50 | 10 | <input type="checkbox"/> | 50 | 10 | <input type="checkbox"/> | <input type="checkbox"/> | <input type="checkbox"/> | WARN |
| <input type="checkbox"/> | 13 | <input type="checkbox"/> | 50 | 10 | <input type="checkbox"/> | 50 | 10 | <input type="checkbox"/> | <input type="checkbox"/> | <input type="checkbox"/> | WARN |
| <input type="checkbox"/> | 14 | <input type="checkbox"/> | 50 | 10 | <input type="checkbox"/> | 50 | 10 | <input type="checkbox"/> | <input type="checkbox"/> | <input type="checkbox"/> | WARN |
| <input type="checkbox"/> | 15 | <input type="checkbox"/> | 50 | 10 | <input type="checkbox"/> | 50 | 10 | <input type="checkbox"/> | <input type="checkbox"/> | <input type="checkbox"/> | WARN |
| <input type="checkbox"/> | 16 | <input type="checkbox"/> | 50 | 10 | <input type="checkbox"/> | 50 | 10 | <input type="checkbox"/> | <input type="checkbox"/> | <input type="checkbox"/> | WARN |

| Setting | Description | Factory Default |
|--------------|--|-----------------|
| Tx Threshold | Specifies the threshold percentage that triggers the Port usage alarm. | 80 |
| Rx Threshold | Valid Range: 1 to 100 | |
| Duration | Specifies the number of seconds that the CPU usage exceeds threshold to trigger CPU Usage alarm Valid Range: 10 to 60 | 10 |
| Action | The ToughNet Secure Router will send notifications to the email server, Syslog, and status report when the corresponding actions are checked | None |
| Severity | Specifies severity of event notification when CPU Usage alarm is triggered | WARN/Warning |

Event Log Settings

This window lets you configure the event log capacity warnings and decide what action to take when an event log has exceeded its storage threshold.

Event Log Settings

Enable Log Capacity Warning at (%)

Warning By: SNMP Trap Email

Event Log Oversize Action :

Apply

Enable Log Capacity Warning

| Setting | Description | Factory Default |
|-----------------------|--|-----------------|
| Log warning threshold | Specify the log capacity warning threshold (in %), based on the total log capacity. When this threshold is exceeded, the system will send a log capacity warning notification. | None |

Event Log Oversize Action

| Setting | Description | Factory Default |
|--------------------------------|--|--------------------------------|
| Overwrite The Oldest Event Log | The oldest event log will be overwritten when the event log exceeds 1,000 records. | Overwrite The Oldest Event Log |
| Stop Recording Event Log | Additional events will not be recorded when the event log exceeds 1,000 records. | |

Email Setup

✦ Email Setup

Email Alert Configuration

Mail Server IP/Name

PORT

Account Name

Password

Sender Email Address

1st Recipient Email Address

2nd Recipient Email Address

3rd Recipient Email Address

4th Recipient Email Address

Mail Server IP/Name

| Setting | Description | Factory Default |
|------------|--------------------------------------|-----------------|
| IP address | The IP Address of your email server. | None |

Account Name

| Setting | Description | Factory Default |
|-----------------------|---------------------|-----------------|
| Max. 45 of characters | Your email account. | None |

Password Setting

| Setting | Description | Factory Default |
|----------|-----------------------------|-----------------|
| Password | The email account password. | None |

Email Address

| Setting | Description | Factory Default |
|-----------------------|---|-----------------|
| Max. of 30 characters | You can set up to 4 email addresses to receive alarm emails from the Moxa switch. | None |

Send Test Email

After you complete the email settings, you should first click **Apply** to activate those settings, and then press the **Test** button to verify that the settings are correct.



NOTE

Auto warning e-mail messages will be sent through an authentication protected SMTP server that supports the CRAM-MD5, LOGIN, and PAIN methods of SASL (Simple Authentication and Security Layer) authentication mechanism.

We strongly recommend not entering your Account Name and Account Password if auto warning e-mail messages can be delivered without using an authentication mechanism.

Syslog Server Settings

The Syslog function provides the event logs for the syslog server. The function supports 3 configurable syslog servers and syslog server UDP port numbers. When an event occurs, the event will be sent as a syslog UDP packet to the specified syslog servers. Each Syslog server can be activated separately by selecting the check box and enable it.

Syslog Setting

Enable

Syslog Server 1

Port Destination (1-65535)

Enable

Syslog Server 2

Port Destination (1-65535)

Enable

Syslog Server 3

Port Destination (1-65535)

Syslog Server 1/2/3

| Setting | Description | Factory Default |
|----------------------------------|--|-----------------|
| IP Address | Enter the IP address of Syslog server 1/2/3, used by your network. | None |
| Port Destination (1 to 65535) | Enter the UDP port of Syslog server 1/2/3. | 514 |



NOTE

The following events will be recorded into the Moxa ToughNet Secure Router's Event Log table, and will then be sent to the specified Syslog Server:

- Cold start
- Warm start
- Configuration change activated
- Power 1/2 transition (Off (On), Power 1/2 transition (On (Off))
- Authentication fail
- Port link off/on

Relay Warning Status

When relay warning triggered by either system or port events, administrator can decide to shut down the hardware warning buzzer by clicking **Apply** button. The event still be recorded in the event list.

Relay Warning Status

Relay 1 Alarm Cut-Off(ACO)

Relay 2 Alarm Cut-Off(ACO)

Apply

| Index | Event | Relay |
|-------|-------|-------|
|-------|-------|-------|

System File Update—by Remote TFTP

The ToughNet Secure Router supports saving your configuration file to a remote TFTP server or local host to allow other ToughNet Secure Routers to use the same configuration at a later time, or saving the Log file for future reference. Loading pre-saved firmware or a configuration file from the TFTP server or local host is also supported to make it easier to upgrade or configure the ToughNet Secure Router.

Upgrade Software or Configuration

TFTP Server IP/Name

Configuration File Path and Name **Download** **Upload**

Firmware File Path and Name **Download**

Log File Path and Name **Upload**

TFTP Server IP/Name

| Setting | Description | Factory Default |
|---------------------------|---|-----------------|
| IP Address of TFTP Server | The IP or name of the remote TFTP server. Must be configured before downloading or uploading files. | None |

Configuration File Path and Name

| Setting | Description | Factory Default |
|--------------------|--|-----------------|
| Max. 40 Characters | The path and filename of the ToughNet Secure Router's configuration file in the TFTP server. | None |

Firmware File Path and Name

| Setting | Description | Factory Default |
|--------------------|---|-----------------|
| Max. 40 Characters | The path and filename of the ToughNet Secure Router's firmware file | None |

Log File Path and Name

| Setting | Description | Factory Default |
|--------------------|--|-----------------|
| Max. 40 Characters | The path and filename of the ToughNet Secure Router's log file | None |

After setting up the desired path and filename, click **Activate** to save the setting. Next, click **Download** to download the file from the remote TFTP server, or click **Upload** to upload a file to the remote TFTP server.

System File Update—by Local Import/Export

Upgrade Software or Configuration

Export Log File

Import Firmware No file chosen

Export Configuration Version

Export Configuration File

Import Configuration File No file chosen

Text-Based configuration file encryption setting

EnablePassword



NOTE

Some operating systems will open the configuration file and log file directly in the web page. In such cases, right-click the **Export** button and then save as a file.

Export Log File

Click **Export** to export the log file of the ToughNet Secure Router to the local host.

Import Firmware

Click **Choose File** to select a firmware file on the computer's local storage. The upgrade procedure will proceed automatically after clicking **Import**. This upgrade procedure will take several minutes to complete, including boot-up time.

Export Configuration Version

Enter a name for the exported configuration file for version control purposes. This name will be written into the exported configuration file, as shown in the image below.

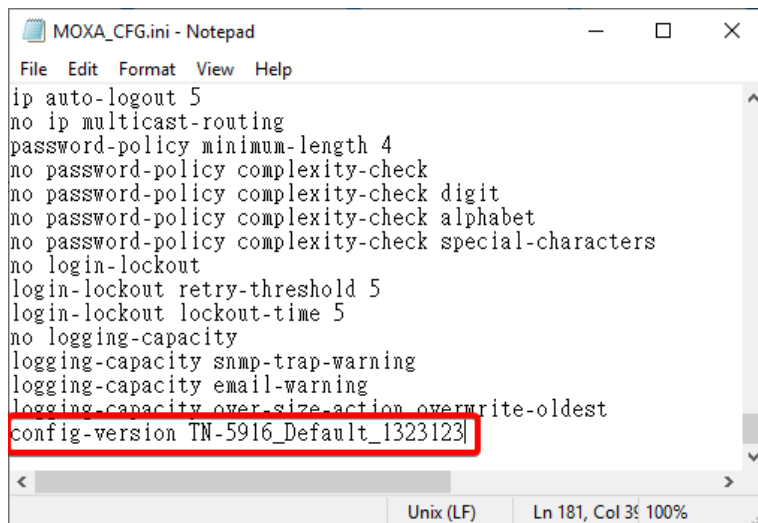

```
MOXA_CFG.ini - Notepad
File Edit Format View Help
ip auto-logout 5
no ip multicast-routing
password-policy minimum-length 4
no password-policy complexity-check
no password-policy complexity-check digit
no password-policy complexity-check alphabet
no password-policy complexity-check special-characters
no login-lockout
login-lockout retry-threshold 5
login-lockout lockout-time 5
no logging-capacity
logging-capacity snmp-trap-warning
logging-capacity email-warning
logging-capacity over-size-action overwrite-oldest
config-version TN-5916_Default_1323123
Unix (LF) Ln 181, Col 39 100%
```

Export Configuration File

Click **Export** to export the configuration file of the ToughNet Secure Router to the local host.

Import Configuration File

Click **Choose File** to select a configuration file on the computer's local storage. The upgrade procedure will proceed automatically after clicking **Import**.

Text-Based configuration file encryption setting

Check **EnablePassword**, enter an encryption password, and click **Apply**. When exporting configuration file, the file will be encrypted with this password. Leaving this field blank will not apply any encryption.

Back Up Media

You can use the Moxa Auto-Backup Configurator (ABC) to quickly save and load ToughNet Secure Router configurations through the router's RS-232 console port.

ABC (Auto-Backup Configurator) Configuration

Auto load ABC's system configurations when system boots up Apply

Save the current configurations to ABC Export

Load the ABC's configurations to Switch Import

Restart

Restart

This function will restart the system.

Apply

This function is used to restart the ToughNet Secure Router.

Reset to Factory Default

Reset to Factory Default

This function will reset all settings to their factory default values.
Be aware that previous settings will be lost.

Keep "Certificate Management" and "Authentication Certificate" configuration

Apply

The **Reset to Factory Default** option gives users a quick way of restoring the ToughNet Secure Router's configuration settings to the factory default values. This function is available in the console utility (serial or Telnet), and web browser interface.



NOTE

After activating the Factory Default function, you will need to use the default network settings to re-establish a web-browser or Telnet connection with your ToughNet Secure Router. Optionally, check **Keep "Certificate Management" and "Authentication Certificate"** configuration to keep these configuration settings when resetting the router to default settings.

Port

Port Settings

Port settings are included to give the user control over port access, port transmission speed, flow control, and port type (MDI or MDIX).

| Port Setting | | | | | | | |
|--------------|-------------------------------------|------------|-------------|-------|---------------|----------|--|
| Port | Enable | Media Type | Description | Speed | FDX Flow ctrl | MDI/MDIX | |
| 1 | <input checked="" type="checkbox"/> | 100TX | | Auto | Disable | Auto | |
| 2 | <input checked="" type="checkbox"/> | 100TX | | Auto | Disable | Auto | |
| 3 | <input checked="" type="checkbox"/> | 100TX | | Auto | Disable | Auto | |
| 4 | <input checked="" type="checkbox"/> | 100TX | | Auto | Disable | Auto | |
| 5 | <input checked="" type="checkbox"/> | 100TX | | Auto | Disable | Auto | |
| 6 | <input checked="" type="checkbox"/> | 100TX | | Auto | Disable | Auto | |
| 7 | <input checked="" type="checkbox"/> | 100TX | | Auto | Disable | Auto | |
| 8 | <input checked="" type="checkbox"/> | 100TX | | Auto | Disable | Auto | |
| 9 | <input checked="" type="checkbox"/> | 100TX | | Auto | Disable | Auto | |
| 10 | <input checked="" type="checkbox"/> | 100TX | | Auto | Disable | Auto | |
| 11 | <input checked="" type="checkbox"/> | 100TX | | Auto | Disable | Auto | |
| 12 | <input checked="" type="checkbox"/> | 100TX | | Auto | Disable | Auto | |
| 13 | <input checked="" type="checkbox"/> | 100TX | | Auto | Disable | Auto | |
| 14 | <input checked="" type="checkbox"/> | 100TX | | Auto | Disable | Auto | |
| 15 | <input checked="" type="checkbox"/> | 100TX | | Auto | Disable | Auto | |
| 16 | <input checked="" type="checkbox"/> | 100TX | | Auto | Disable | Auto | |

Enable

| Setting | Description | Factory Default |
|-----------|--|-----------------|
| Checked | Allows data transmission through the port. | Enabled |
| Unchecked | Immediately shuts off port access. | |

Media Type

| Setting | Description | Factory Default |
|------------|--|-----------------|
| Media type | Displays the media type for each module's port | N/A |

Description

| Setting | Description | Factory Default |
|--------------------|--|-----------------|
| Max. 63 characters | Specifies an alias for the port to help administrators differentiate between different ports. Example: PLC 1 | None |

Speed

| Setting | Description | Factory Default |
|-----------|--|-----------------|
| Auto | Allows the port to use the IEEE 802.3u protocol to negotiate with connected devices. The port and connected devices will determine the best speed for that connection. | Auto |
| 100M-Full | | |

| Setting | Description | Factory Default |
|-----------|---|-----------------|
| 100M-Half | Choose one of these fixed speed options if the connected Ethernet device has trouble auto-negotiating for line speed. | |
| 10M-Full | | |
| 10M-Half | | |

FDX Flow Ctrl

This setting enables or disables flow control for the port when the port's Speed is set to Auto. The final result will be determined by the Auto process between the Moxa switch and connected devices.

| Setting | Description | Factory Default |
|---------|---|-----------------|
| Enable | Enables flow control for this port when the port's Speed is set to Auto. | Disabled |
| Disable | Disables flow control for this port when the port's Speed is set to Auto. | |

MDI/MDIX

| Setting | Description | Factory Default |
|---------|---|-----------------|
| Auto | Allows the port to auto-detect the port type of the connected Ethernet device and change the port type accordingly. | Auto |
| MDI | Choose MDI or MDIX if the connected Ethernet device has trouble auto-negotiating for port type. | |
| MDIX | | |

Port Status

From the **Port Status** window, you can view detailed port status information including the port number, media type, link status, MDI/MDIX mode, FDX Flow Control status, and the current port state.

 **Port Status**

| Port | Media Type | Link Status | MDI/MDIX | FDX Flow ctrl | Port State |
|------|------------|-------------|----------|---------------|------------|
| 1/1 | 100TX | -- | -- | -- | Forwarding |
| 1/2 | 100TX | -- | -- | -- | Forwarding |
| 1/3 | 100TX | -- | -- | -- | Forwarding |
| 1/4 | 100TX | -- | -- | -- | Forwarding |
| 1/5 | 100TX | -- | -- | -- | Forwarding |
| 1/6 | 100TX | -- | -- | -- | Forwarding |
| 1/7 | 100TX | 100M-Full | MDIX | Off | Forwarding |
| 1/8 | 100TX | -- | -- | -- | Forwarding |
| 1/9 | 100TX | -- | -- | -- | Forwarding |
| 1/10 | 100TX | -- | -- | -- | Forwarding |
| 1/11 | 100TX | -- | -- | -- | Forwarding |
| 1/12 | 100TX | -- | -- | -- | Forwarding |
| 1/13 | 100TX | -- | -- | -- | Forwarding |
| 1/14 | 100TX | -- | -- | -- | Forwarding |
| 1/15 | 100TX | -- | -- | -- | Forwarding |
| 1/16 | 100TX | -- | -- | -- | Forwarding |

Link Aggregation

Link aggregation involves grouping links into a link aggregation group. A MAC client can treat link aggregation groups as if they were a single link.

The Moxa ToughNet Secure Router’s port trunking feature allows devices to communicate by aggregating up to 2 trunk groups, with a maximum of 8 ports for each group. If one of the 8 ports fails, the other seven ports will automatically provide backup and share the traffic.

Port trunking can be used to combine up to 8 ports between two Moxa switches or ToughNet Secure Routers. If all ports on both switches are configured as 100BaseTX and they are operating in full duplex, the potential bandwidth of the connection will be 1600 Mbps.

The Port Trunking Concept

Moxa has developed a port trunking protocol that provides the following benefits:

- Greater flexibility in setting up your network connections, since the bandwidth of a link can be doubled, tripled, or quadrupled.
- Redundancy—if one link is broken, the remaining trunked ports share the traffic within this trunk group.
- Load sharing—MAC client traffic can be distributed across multiple links.

To avoid broadcast storms or loops in your network while configuring a trunk, first disable or disconnect all ports that you want to add to the trunk or remove from the trunk. After you finish configuring the trunk, enable or re-connect the ports.

If all ports on both switch units are configured as 100BaseTX and they are operating in full duplex mode, the potential bandwidth of the connection will be up to 1.6 Gbps. This means that users can double, triple, or quadruple the bandwidth of the connection by port trunking between two Moxa switches.

Each Moxa ToughNet Secure Router can set a maximum of 2 port trunking groups. When you activate port trunking, certain settings on each port will be reset to factory default values or disabled:

- Communication redundancy will be reset
- 802.1Q VLAN will be reset
- Multicast Filtering will be reset
- Port Lock will be reset and disabled.
- Set Device IP will be reset
- Mirror will be reset

After port trunking has been activated, you can configure these items again for each trunking port.

Port Trunking

The **Port Trunking Settings** page is where ports are assigned to a trunk group.

Step 1: Select the desired **Trunk Group**.

Step 2: Select the desired **Member Ports** or **Available Ports**.

Step 3: Use **Up** and **Down** to modify the Group Members.

Trunk Group (maximum of 2 trunk groups)

| Setting | Description | Factory Default |
|--|------------------------------------|-----------------|
| Trk1, Trk2 (depends on switching chip capability) | Specifies the current trunk group. | Trk1 |

Trunking Status

The **Trunking Status table** shows the Trunk Group configuration status.

| Trunking Status | | |
|-----------------|-------------|---------|
| Trunk Group | Member Port | Status |
| Trk1 | 1 | Success |
| | 2 | Success |
| Trk2 | 3 | Fail |
| | 5 | Fail |

Port Mirror

The **Port Mirror** function can be used to monitor data being transmitted through a specific port. This is done by setting up another port (the mirror port) to receive the same data being transmitted from, or both to and from, the port under observation. Using a mirror port allows the network administrator to **sniff** the observed port to keep tabs on network activity.

Port Mirroring

Monitored port

Watch direction

Mirror Port

Port 1

Port 2

Port 3

Port 4

Port 5

Port 6

Port 7

Port 8

Port 9

Port 10

Port 11

Port 12

Port 13

Port 14

Port 15

Port 16

Bi-directional

Port Mirroring Settings

| Setting | Description |
|-----------------|---|
| Monitored Port | Select the number of the ports whose network activity will be monitored. Multiple port selection is acceptable. |
| Watch Direction | <p>Select one of the following two watch direction options:</p> <ul style="list-style-type: none"> Input data stream: Select this option to monitor only those data packets coming into the Moxa ToughNet Secure Router's port. Output data stream: Select this option to monitor only those data packets being sent out through the Moxa ToughNet Secure Router's port. Bi-directional: Select this option to monitor data packets both coming into, and being sent out through, the Moxa ToughNet Secure Router's port. |
| Mirror Port | Select the number of the port that will be used to monitor the activity of the monitored port. |

Using Virtual LAN

Setting up Virtual LANs (VLANs) on your Moxa ToughNet Secure Router increases the efficiency of your network by dividing the LAN into logical segments, as opposed to physical segments. In general, VLANs are easier to manage.

The VLAN Concept

What is a VLAN?

A VLAN is a group of devices that can be located anywhere on a network, but which communicate as if they are on the same physical segment. With VLANs, you can segment your network without being restricted by physical connections—a limitation of traditional network design. With VLANs you can segment your network into:

- **Departmental groups**—you could have one VLAN for the marketing department, another for the finance department, and another for the product development department.
- **Hierarchical groups**—you could have one VLAN for directors, another for managers, and another for general staff.
- **Usage groups**—you could have one VLAN for email users and another for multimedia users.

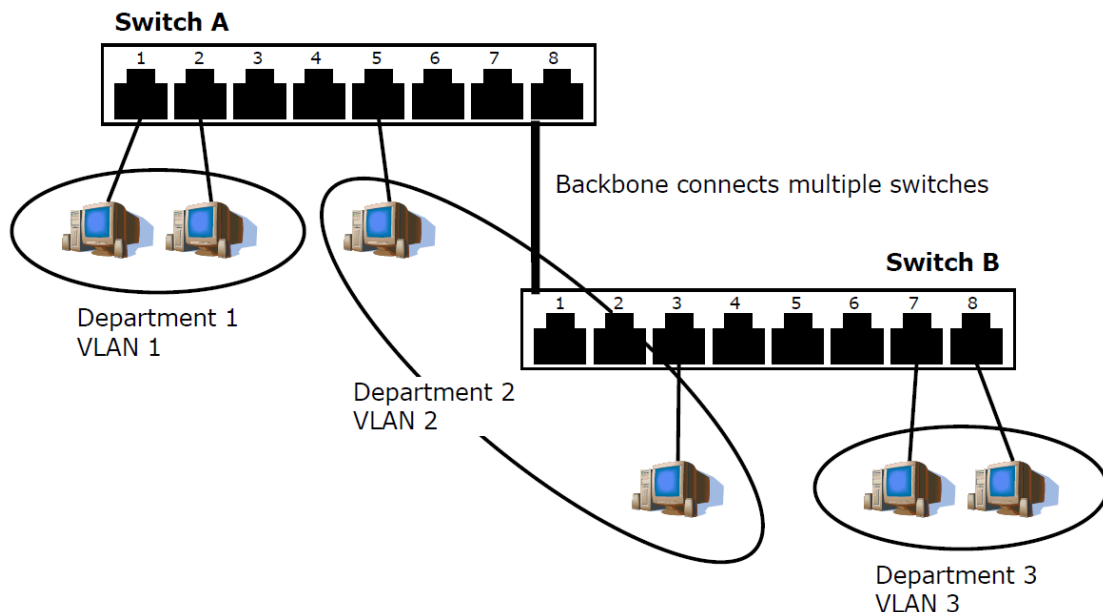

Benefits of VLANs

The main benefit of VLANs is that they provide a network segmentation system that is far more flexible than traditional networks. Using VLANs also provides you with three other benefits:

- **VLANs ease the relocation of devices on networks:** With traditional networks, network administrators spend much of their time dealing with moves and changes. If users move to a different sub-network, the addresses of each host must be updated manually. With a VLAN setup, if a host originally on VLAN Marketing, for example, is moved to a port on another part of the network, and retains its original subnet membership, you only need to specify that the new port is on VLAN Marketing. You do not need to do any re-cabling.
- **VLANs provide extra security:** Devices within each VLAN can only communicate with other devices on the same VLAN. If a device on VLAN Marketing needs to communicate with devices on VLAN Finance, the traffic must pass through a routing device or Layer 3 switch.
- **VLANs help control traffic:** With traditional networks, congestion can be caused by broadcast traffic that is directed to all network devices, regardless of whether or not they need it. VLANs increase the efficiency of

your network because each VLAN can be set up to contain only those devices that need to communicate with each other.

Managing a VLAN

A new or initialized Moxa ToughNet Secure Router contains a single VLAN—the Default VLAN. This VLAN has the following definition:

- **VLAN Name**—Management VLAN
- **802.1Q VLAN ID**—1 (if tagging is required)

All of the ports are initially placed on this VLAN, and it is the only VLAN that allows you to access the management software of the Moxa switch over the network.

Configuring Virtual LAN

To configure **802.1Q VLAN** on the Moxa switch, use the **802.1Q VLAN Settings** page to configure the ports.

802.1Q VLAN Settings

| Port | Type | PVID | Fixed VLAN (Tagged) | Fixed VLAN (Untagged) |
|------|--------|------|---------------------|-----------------------|
| 1 | Access | 1 | | |
| 2 | Access | 1 | | |
| 3 | Access | 1 | | |
| 4 | Access | 1 | | |
| 5 | Access | 1 | | |
| 6 | Access | 1 | | |
| 7 | Access | 1 | | |
| 8 | Access | 1 | | |
| 9 | Access | 1 | | |
| 10 | Access | 1 | | |
| 11 | Access | 1 | | |
| 12 | Access | 1 | | |
| 13 | Access | 1 | | |
| 14 | Access | 1 | | |
| 15 | Access | 1 | | |
| 16 | Access | 16 | | |

Apply

Management VLAN ID

| Setting | Description | Factory Default |
|---------------------|--|-----------------|
| VLAN ID from 1-4094 | Assigns the VLAN ID of this Moxa switch. | 1 |

Port Type

| Setting | Description | Factory Default |
|---------|---|-----------------|
| Access | Port type is used to connect single devices without tags. | Access |

| Setting | Description | Factory Default |
|---------|---|-----------------|
| Trunk | Select Trunk port type to connect another 802.1Q VLAN aware switch. | |
| Hybrid | Select Hybrid port to connect another Access 802.1Q VLAN aware switch or another LAN that combines tagged and/or untagged devices and/or other switches/hubs. | |

PVID

| Setting | Description | Factory Default |
|---------------------|---|-----------------|
| VLAN ID from 1-4094 | Sets the default VLAN ID for untagged devices that connect to the port. | 1 |

Tagged VLAN

| Setting | Description | Factory Default |
|---------------------|---|-----------------|
| VLAN ID from 1-4094 | This field will be active only when selecting the Trunk or Hybrid port type. Set the other VLAN ID for tagged devices that connect to the port. Use commas to separate different VLANs. | None |

Untagged VLAN

| Setting | Description | Factory Default |
|---------------------|--|-----------------|
| VLAN ID from 1-4094 | This field will be active only when selecting the Trunk or Hybrid port type. Set the other VLAN ID for tagged devices that connect to the port and tags that need to be removed in egress packets. Use commas to separate different VLANs. | None |

VLAN Table

| VLAN Table | | | | | |
|------------|-----|--------------------|-------------------|--------------------|--------|
| Index | VID | Joined Access Port | Joined Trunk Port | Joined Hybrid Port | Action |
| 1 | *1 | 1,2,3,7,G1,G2, | | | |
| 2 | 2 | 4,5, | | | |
| 3 | 3 | 6,8, | | | |

Use the **802.1Q VLAN Table** to review the VLAN groups that were created, Joined Access Ports, Trunk Ports, and Hybrid Ports, and also Action for deleting VLANs which have no member ports in the list.

Multicast

Multicast filtering improves the performance of networks that carry multicast traffic. This section explains multicasts, multicast filtering, and how multicast filtering can be implemented on your Moxa ToughNet Secure Router.

The Concept of Multicast Filtering

What is an IP Multicast?

A *multicast* is a packet sent by one host to multiple hosts. Only those hosts that belong to a specific multicast group will receive the multicast. If the network is set up correctly, a multicast can only be sent to an end-station or a subset of end-stations on a LAN or VLAN that belong to the multicast group. Multicast group members can be distributed across multiple subnets, so that multicast transmissions can occur within a campus LAN or over a WAN. In addition, networks that support IP multicast send only *one* copy of the desired information across the network until the delivery path that reaches group members diverges. To make more efficient use of network bandwidth, it is only at these points that multicast packets are duplicated and forwarded. A multicast packet has a multicast group address in the destination address field of the packet's IP header.

Benefits of Multicast

The benefits of using IP multicast are:

- It uses the most efficient, sensible method to deliver the same information to many receivers with only one transmission.
- It reduces the load on the source (for example, a server) since it will not need to produce several copies of the same data.
- It makes efficient use of network bandwidth and scales well as the number of multicast group members increases.
- Works with other IP protocols and services, such as Quality of Service (QoS).

Multicast transmission makes more sense and is more efficient than unicast transmission for some applications. For example, multicasts are often used for video-conferencing, since high volumes of traffic must be sent to several end-stations at the same time, but where broadcasting the traffic to all end-stations would cause a substantial reduction in network performance. Furthermore, several industrial automation protocols, such as Allen-Bradley, EtherNet/IP, Siemens Profibus, and Foundation Fieldbus HSE (High Speed Ethernet), use multicast. These industrial Ethernet protocols use publisher/subscriber communications models by multicasting packets that could flood a network with heavy traffic. IGMP Snooping is used to prune multicast traffic so that it travels only to those end destinations that require the traffic, reducing the amount of traffic on the Ethernet LAN.

Multicast Filtering

Multicast filtering ensures that only end-stations that have joined certain groups receive multicast traffic. With multicast filtering, network devices only forward multicast traffic to the ports that are connected to registered end-stations. The following two figures illustrate how a network behaves without multicast filtering, and with multicast filtering.

Network without multicast filtering

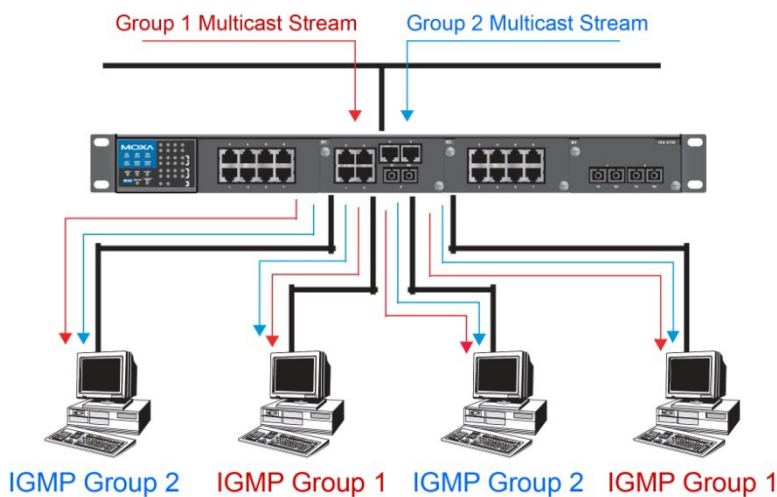

All hosts receive the multicast traffic, even if they don't need it.

Network with multicast filtering

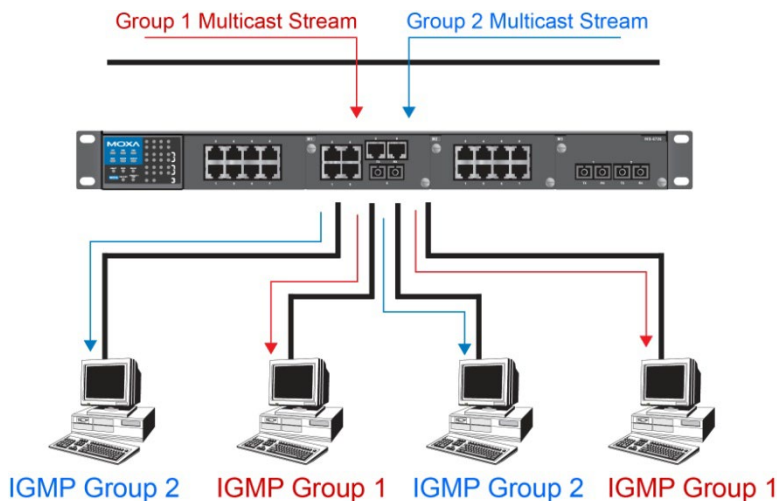

Hosts only receive dedicated traffic from other hosts belonging to the same group.

Multicast Filtering and Moxa's ToughNet Secure Routers

The Moxa ToughNet Secure Router has two ways to achieve multicast filtering: IGMP (Internet Group Management Protocol) Snooping and adding a static multicast MAC manually to filter multicast traffic automatically.

Snooping Mode

Snooping Mode allows your ToughNet Secure Router to forward multicast packets only to the appropriate ports. The router **snoops** on exchanges between hosts and an IGMP device to find those ports that want to join a multicast group, and then configures its filters accordingly.

Query Mode

Query mode allows the Moxa router to work as the Querier if it has the lowest IP address on the subnetwork to which it belongs.

IGMP querying is enabled by default on the Moxa router to ensure proceeding query election. Enable query mode to run multicast sessions on a network that does not contain IGMP routers (or queriers). Query mode allows users to enable IGMP snooping by VLAN ID. Moxa ToughNet Secure Router support IGMP snooping version 1 and version 2. Version 2 is compatible with version 1. The default setting is IGMP V1/V2. "

IGMP Multicast Filtering

IGMP is used by IP-supporting network devices to register hosts with multicast groups. It can be used on all LANs and VLANs that contain a multicast capable IP router, and on other network devices that support multicast filtering. Moxa switches support IGMP version 1 and 2. IGMP version 1 and 2 work as follows:

- The IP router (or querier) periodically sends query packets to all end-stations on the LANs or VLANs that are connected to it. For networks with more than one IP router, the router with the lowest IP address is the querier. A switch with IP address lower than the IP address of any other IGMP queriers connected to the LAN or VLAN can become the IGMP querier.
- When an IP host receives a query packet, it sends a report packet back that identifies the multicast group that the end-station would like to join.
- When the report packet arrives at a port on a switch with IGMP Snooping enabled, the switch knows that the port should forward traffic for the multicast group, and then proceeds to forward the packet to the router.
- When the router receives the report packet, it registers that the LAN or VLAN requires traffic for the multicast groups.
- When the router forwards traffic for the multicast group to the LAN or VLAN, the switches only forward the traffic to ports that received a report packet.

IGMP version comparison

| IGMP Version | Main Features | Reference |
|--------------|---|-----------|
| V1 | a. Periodic query | RFC-1112 |
| V2 | Compatible with V1 and adds: a. Group-specific query b. Leave group messages c. Resends specific queries to verify leave message was the last one in the group d. Querier election | RFC-2236 |

Static Multicast MAC

Some devices may only support multicast packets, but not support either IGMP Snooping. The Moxa ToughNet Secure Router supports adding multicast groups manually to enable multicast filtering.

Enabling Multicast Filtering

Use the USB console or web interface to enable or disable IGMP Snooping and IGMP querying. If IGMP Snooping is not enabled, then IP multicast traffic is always forwarded, flooding the network.

IGMP Snooping

IGMP Snooping provides the ability to prune multicast traffic so that it travels only to those end destinations that require that traffic, thereby reducing the amount of traffic on the Ethernet LAN.

IGMP Snooping Settings



Enable IGMP Snooping (Global)

| Setting | Description | Factory Default |
|----------------|---|-----------------|
| Enable/Disable | Checkmark the Enable IGMP Snooping checkbox near the top of the window to enable the IGMP Snooping function globally. | Disabled |

Query Interval (sec)

| Setting | Description | Factory Default |
|------------------------------------|--|-----------------|
| Numerical value, input by the user | Sets the query interval of the Querier function globally. Valid settings are from 20 to 600 seconds. | 125 seconds |

Enable Syslog

| Setting | Description | Factory Default |
|----------------|--|-----------------|
| Enable/Disable | Send IGMP Snooping log message to syslog server. | Disabled |

Enable IGMP Snooping

| Setting | Description | Factory Default |
|----------------|---|--|
| Enable/Disable | Enables or disables the IGMP Snooping function on that particular VLAN. | Enabled if IGMP Snooping is enabled globally |

Querier

| Setting | Description | Factory Default |
|----------------|--|-----------------|
| Enable/Disable | Enables or disables the Moxa ToughNet Secure Router's querier function. | Disabled |
| V1/V2 Checkbox | V1/V2: Enables the Moxa ToughNet Secure Router to send IGMP snooping version 1 and 2 queries | V1/V2 |

Static Multicast Querier Port

| Setting | Description | Factory Default |
|-----------------|--|-----------------|
| Select/Deselect | Select the ports that will connect to the multicast routers. These ports will receive all multicast packets from the source. This option is only active when IGMP Snooping is enabled. | Disabled |



NOTE

If a router or layer 3 switch is connected to the network, it will act as the Querier, and consequently this Querier option will be disabled on all Moxa layer 2 switches.

If all switches on the network are Moxa layer 2 switches, then only one layer 2 switch will act as Querier.



NOTE

When DVMRP is enabled on the Toughnet Secure Router, IGMP snooping must be configured on the other network device for the feature to function.

IGMP Table

The Moxa ToughNet Secure Router displays the current active IGMP groups that were detected. View IGMP group setting per VLAN ID on this page.

| IGMP Snooping IGMP Table | | | | | | | |
|------------------------------------|-------|------------------------------|---------|------------------------|---------|----------------|--|
| VID: 1 | | | | | | | |
| Auto Learned Multicast Router Port | | Static Multicast Router Port | | Querier Connected Port | | Act as Querier | |
| | | | | | | No | |
| Index | Group | Port | Version | Filter Mode | Sources | | |

The information shown in the table includes:

- Auto Learned Multicast Router Port: This indicates that a multicast router connects to/sends packets from these port(s).
- Static Multicast Router Port: Displays the static multicast querier port(s)
- Querier Connected Port: Displays the port which is connected to the querier
- Act as a Querier: Displays whether or not this VLAN is a querier (winner of an election)
- Group: Displays the multicast group addresses
- Port: Displays the port that receives the multicast stream/the port the multicast stream is forwarded to
- Version: Displays the IGMP Snooping version

Stream Table

This page displays the multicast stream forwarding status. It allows you to view the status per VLAN ID.

| IGMP Snooping Stream Table | | | | |
|----------------------------|--------------|---------------|------|--------------|
| Index | Stream Group | Stream Source | Port | Member Ports |

Stream Group: Multicast group IP address

Stream Source: Multicast source IP address

Port: Which port receives the multicast stream

Member ports: Ports the multicast stream is forwarded to

Static Multicast MAC

Static Multicast MAC Address

Add New Static Multicast MAC Address to the List
 01:00:5E:XX:XX:XX in here is IP multicast MAC address, please activate IGMP Snooping for automatic classification

Mac Address

Join Port

Port 1 Port 2 Port 3 Port 4 Port 5
 Port 6 Port 7 Port 8 Port 9 Port 10
 Port 11 Port 12 Port 13 Port 14 Port 15
 Port 16

Current Static Multicast MAC Address List (0/128)

| MAC Address | Port | | | | | | | | | | | | | | | |
|-------------|------|---|---|---|---|---|---|---|---|----|----|----|----|----|----|----|
| | 1 | 2 | 3 | 4 | 5 | 6 | 7 | 8 | 9 | 10 | 11 | 12 | 13 | 14 | 15 | 16 |



NOTE

01:00:5E:XX:XX:XX on this page is the IP multicast MAC address. Please activate IGMP Snooping for automatic classification.

MAC Address

| Setting | Description | Factory Default |
|---------|--|-----------------|
| Integer | Input the number of the VLAN that the host with this MAC address belongs to. | None |

Join Port

| Setting | Description | Factory Default |
|-----------------|--|-----------------|
| Select/Deselect | Checkmark the appropriate check boxes to select the join ports for this multicast group. | None |

QoS

QoS Classification

QoS Classification

Scheduling Mechanism: Weight Fair(8:4:2:1)

| Port | Port Highest Priority | Inspect ToS | Inspect CoS |
|------|--------------------------|--------------------------|--------------------------|
| 1 | <input type="checkbox"/> | <input type="checkbox"/> | <input type="checkbox"/> |
| 2 | <input type="checkbox"/> | <input type="checkbox"/> | <input type="checkbox"/> |
| 3 | <input type="checkbox"/> | <input type="checkbox"/> | <input type="checkbox"/> |
| 4 | <input type="checkbox"/> | <input type="checkbox"/> | <input type="checkbox"/> |
| 5 | <input type="checkbox"/> | <input type="checkbox"/> | <input type="checkbox"/> |
| 6 | <input type="checkbox"/> | <input type="checkbox"/> | <input type="checkbox"/> |
| 7 | <input type="checkbox"/> | <input type="checkbox"/> | <input type="checkbox"/> |
| 8 | <input type="checkbox"/> | <input type="checkbox"/> | <input type="checkbox"/> |
| 9 | <input type="checkbox"/> | <input type="checkbox"/> | <input type="checkbox"/> |
| 10 | <input type="checkbox"/> | <input type="checkbox"/> | <input type="checkbox"/> |
| 11 | <input type="checkbox"/> | <input type="checkbox"/> | <input type="checkbox"/> |
| 12 | <input type="checkbox"/> | <input type="checkbox"/> | <input type="checkbox"/> |

Apply

The Moxa switch supports inspection of layer 3 ToS and/or layer 2 CoS tag information to determine how to classify traffic packets.

Scheduling Mechanism

| Setting | Description | Factory Default |
|-------------|--|-----------------|
| Weight Fair | The Moxa ToughNet Secure Router has 4 priority queues. In the weight fair scheme, an 8, 4, 2, 1 weighting is applied to the four priorities. This approach prevents the lower priority frames from being starved of opportunity for transmission with only a slight delay to the higher priority frames. | Weight Fair |
| Strict | In the Strict-priority scheme, all top-priority frames egress a port until that priority's queue is empty, and then the next lower priority queue's frames egress. This approach can cause the lower priorities to be starved of opportunity for transmitting any frames but ensures that all high priority frames will egress the switch as soon as possible. | |

Inspect ToS

| Setting | Description | Factory Default |
|----------------|--|-----------------|
| Enable/Disable | Enables or disables the Moxa ToughNet Secure Router for inspecting Type of Service (ToS) bits in the IPV4 frame to determine the priority of each frame. | Enabled |

Inspect COS

| Setting | Description | Factory Default |
|----------------|--|-----------------|
| Enable/Disable | Enables or disables the Moxa ToughNet Secure Router for inspecting 802.1p CoS tags in the MAC frame to determine the priority of each frame. | Enabled |

Port Priority

| Setting | Description | Factory Default |
|---------------|---|-----------------|
| Port priority | The port priority has 4 priority queues. Low, normal, medium, high priority queue option is applied to each port. | 3(Normal) |



NOTE

The priority of an ingress frame is determined in the following order:

1. Inspect CoS
2. Inspect ToS
3. Port Priority



NOTE

The designer can enable these classifications individually or in combination. For instance, if a "hot" higher priority port is required for a network design, Inspect TOS and Inspect CoS can be disabled. This setting leaves only port default priority active, which results in all ingress frames being assigned the same priority on that port.

CoS Mapping

CoS Mapping

| CoS | Priority Queue |
|-----|----------------|
| 0 | Low |
| 1 | Low |
| 2 | Normal |
| 3 | Normal |
| 4 | Medium |
| 5 | Medium |
| 6 | High |
| 7 | High |

CoS Value and Priority Queues

| Setting | Description | Factory Default |
|----------------------------|---|---------------------------------|
| Low/Normal/ Medium/High | Maps different CoS values to 4 different egress queues. | Low Normal Medium High |

ToS/DSCP Mapping

ToS/DSCP Mapping

| ToS | Level | ToS | Level | ToS | Level | ToS | Level |
|----------|--------|----------|--------|----------|--------|----------|--------|
| 0x00(1) | Low | 0x04(2) | Low | 0x08(3) | Low | 0x0C(4) | Low |
| 0x10(5) | Low | 0x14(6) | Low | 0x18(7) | Low | 0x1C(8) | Low |
| 0x20(9) | Low | 0x24(10) | Low | 0x28(11) | Low | 0x2C(12) | Low |
| 0x30(13) | Low | 0x34(14) | Low | 0x38(15) | Low | 0x3C(16) | Low |
| 0x40(17) | Normal | 0x44(18) | Normal | 0x48(19) | Normal | 0x4C(20) | Normal |
| 0x50(21) | Normal | 0x54(22) | Normal | 0x58(23) | Normal | 0x5C(24) | Normal |
| 0x60(25) | Normal | 0x64(26) | Normal | 0x68(27) | Normal | 0x6C(28) | Normal |
| 0x70(29) | Normal | 0x74(30) | Normal | 0x78(31) | Normal | 0x7C(32) | Normal |
| 0x80(33) | Medium | 0x84(34) | Medium | 0x88(35) | Medium | 0x8C(36) | Medium |
| 0x90(37) | Medium | 0x94(38) | Medium | 0x98(39) | Medium | 0x9C(40) | Medium |
| 0xA0(41) | Medium | 0xA4(42) | Medium | 0xA8(43) | Medium | 0xAC(44) | Medium |
| 0xB0(45) | Medium | 0xB4(46) | Medium | 0xB8(47) | Medium | 0xBC(48) | Medium |

Apply

ToS (DSCP) Value and Priority Queues

| Setting | Description | Factory Default |
|----------------------------|---|--|
| Low/Normal/ Medium/High | Maps different TOS values to 4 different egress queues. | 1 to 16: Low 17 to 32: Normal 33 to 48: Medium 49 to 64: High |

Rate Limit

Rate Limiting

| Port | Ingress | Egress |
|------|----------------------------|----------------------------|
| 1 | Not Limited ▼ 100 Mbts/sec | Not Limited ▼ 100 Mbts/sec |
| 2 | Not Limited ▼ 100 Mbts/sec | Not Limited ▼ 100 Mbts/sec |
| 3 | Not Limited ▼ 100 Mbts/sec | Not Limited ▼ 100 Mbts/sec |
| 4 | Not Limited ▼ 100 Mbts/sec | Not Limited ▼ 100 Mbts/sec |
| 5 | Not Limited ▼ 100 Mbts/sec | Not Limited ▼ 100 Mbts/sec |
| 6 | Not Limited ▼ 100 Mbts/sec | Not Limited ▼ 100 Mbts/sec |
| 7 | Not Limited ▼ 100 Mbts/sec | Not Limited ▼ 100 Mbts/sec |
| 8 | Not Limited ▼ 100 Mbts/sec | Not Limited ▼ 100 Mbts/sec |
| 9 | Not Limited ▼ 100 Mbts/sec | Not Limited ▼ 100 Mbts/sec |
| 10 | Not Limited ▼ 100 Mbts/sec | Not Limited ▼ 100 Mbts/sec |
| 11 | Not Limited ▼ 100 Mbts/sec | Not Limited ▼ 100 Mbts/sec |
| 12 | Not Limited ▼ 100 Mbts/sec | Not Limited ▼ 100 Mbts/sec |
| 13 | Not Limited ▼ 100 Mbts/sec | Not Limited ▼ 100 Mbts/sec |
| 14 | Not Limited ▼ 100 Mbts/sec | Not Limited ▼ 100 Mbts/sec |
| 15 | Not Limited ▼ 100 Mbts/sec | Not Limited ▼ 100 Mbts/sec |
| 16 | Not Limited ▼ 100 Mbts/sec | Not Limited ▼ 100 Mbts/sec |

Apply

Ingress and Egress Rate Limit-Normal

| Setting | Description | Factory Default |
|--------------|--|-----------------|
| Ingress rate | Select the ingress/egress rate limit (% of max. throughput) for all packets from the following options: Not Limited, 3%, 5%, 10%, 15%, 25%, 35%, 50%, 65%, 85% | Not Limited |
| Egress rate | | |

MAC Address Table

The MAC address table shows the MAC address list pass through Moxa ToughNet Secure Router. The length of time(Ageing time: 15 to 3825 seconds) is the parameter defines the length of time that a MAC address

entry can remain in the Moxa router. When an entry reaches its aging time, it “ages out” and is purged from the router, effectively cancelling frame forwarding to that specific port.

The MAC Address table can be configured to display the following Moxa ToughNet Secure Router MAC address groups, which are selected from the drop-down list.

All MAC Address List

Age Time (s)

All

| Index | MAC Address | Type | Port |
|-------|-------------------|----------|------|
| 1 | 00:90:e8:29:ad:95 | ucast(l) | 2 |
| 2 | 00:90:e8:2c:19:6d | ucast(l) | 4 |
| 3 | 00:90:e8:2c:19:a8 | ucast(l) | 3 |
| 4 | 00:90:e8:2c:19:c3 | ucast(l) | 1 |

Drop Down List

| | |
|----------------------|--|
| ALL | Select this item to show all of the Moxa ToughNet Secure Router’s MAC addresses. |
| ALL Learned | Select this item to show all of the Moxa ToughNet Secure Router’s Learned MAC addresses. |
| ALL Static | Select this item to show all of the Moxa ToughNet Secure Router’s Static, Static Lock, and Static Multicast MAC addresses. |
| ALL Multicast | Select this item to show all of the Moxa ToughNet Secure Router’s Static Multicast MAC addresses. |
| Port x | Select this item to show all of the MAC addresses dedicated ports. |

The table displays the following information:

| | |
|--------------------|---|
| MAC Address | This field shows the MAC address. |
| Type | This field shows the type of this MAC address. |
| Port | This field shows the port that this MAC address belongs to. |

Interface

WAN

WAN Configuration

VLAN ID
----- ▼

Address Information

Connect Type: Dynamic IP ▼
IP Address: 0.0.0.0
Gateway: 0.0.0.0
Subnet Mask: 0.0.0.0

DNS Setup

Server 1: 0.0.0.0
Server 2: 0.0.0.0
Server 3: 0.0.0.0

DHCP Client Option 66/67
Enable:

Apply

VLAN ID

| Setting | Description | Factory Default |
|---------|--|-----------------|
| VLAN ID | Moxa ToughNet Secure Router's WAN interface is configured by VLAN groups. The ports with the same VLAN can be configured as one WAN interface. | N/A |

Address Information

Connect Type

| Setting | Description | Factory Default |
|----------------------|---|-----------------|
| Dynamic IP/Static IP | Select the connection type of the WAN interface | Dynamic IP |

IP Address

| Setting | Description | Factory Default |
|------------|--------------------------|-----------------|
| IP Address | The interface IP address | 0.0.0.0 |

Gateway

| Setting | Description | Factory Default |
|------------|----------------------------------|-----------------|
| IP Address | The interface gateway IP address | 0.0.0.0 |

Subnet Mask

| Setting | Description | Factory Default |
|------------|-----------------|-----------------|
| IP Address | The subnet mask | 0.0.0.0 |

DNS Setup

Server 1/2/3

| Setting | Description | Factory Default |
|------------|--|-----------------|
| IP Address | The IP address of DNS server 1, 2, and 3 | 0.0.0.0 |

DHCP Client Option 66/67

Enable

| Setting | Description | Factory Default |
|----------------|--|-----------------|
| Enable/Disable | Enable or disable DHCP Client Option 66/67 | Disabled |

LAN

LAN Configuration

LAN IP Configuration

Name:

Enable:

Connect Type:

Option 66/67:

VLAN ID:

IP Address:

Subnet Mask:

VLAN Interface List (1/16)

| Name | Enable | Type | VLAN ID | IP Address | Subnet Mask | Option 66/67 |
|------|-------------------------------------|-----------|---------|-----------------|---------------|--------------------------|
| LAN | <input checked="" type="checkbox"/> | Static IP | 1 | 192.168.127.254 | 255.255.255.0 | <input type="checkbox"/> |

Create a VLAN Interface

Input a name of the LAN interface, select a VLAN ID that is already configured in VLAN Setting under the Layer 2 Function, and assign an IP address / Subnet Mask for the interface. Checkmark the **Enable** checkbox to enable this interface.

Delete a LAN Interface

Select the item in the LAN Interface List, and then click **Delete** to delete the item.

Modify a LAN Interface

Select the item in the LAN Interface List. Modify the attributes and then click **Modify** to change the configuration.

Apply the LAN Interface List

After adding/deleting/modifying any LAN interface, be sure to click **Apply**.

Name

| Setting | Description | Factory Default |
|--------------------|-------------------------------|-----------------|
| Max. 40 characters | The name of the LAN interface | LAN |

Enable

| Setting | Description | Factory Default |
|----------------|-------------------------------------|-----------------|
| Enable/Disable | Enable or disable the LAN interface | Enable |

Connect Type

| Setting | Description | Factory Default |
|----------------------|---|-----------------|
| Dynamic IP/Static IP | Select the connection type of the LAN interface | Static IP |

Option 66/67

| Setting | Description | Factory Default |
|----------------|---|-----------------|
| Enable/Disable | Enable or disable Option 66/67 if the Connect Type is set to Dynamic IP | Disable |

VLAN ID

| Setting | Description | Factory Default |
|---------|--|-----------------|
| VLAN ID | Moxa ToughNet Secure Router's LAN interface is configured by VLAN groups. The ports with the same VLAN can be configured as one LAN interface. | VLAN ID |

IP Address

| Setting | Description | Factory Default |
|------------|----------------|-----------------|
| IP Address | The IP address | 192.168.127.254 |

Subnet Mask

| Setting | Description | Factory Default |
|------------|-----------------|-----------------|
| IP Address | The subnet mask | 255.255.255.0 |

Bridge Configuration

Normally, when ports are set in the same network (same subnet/VLAN), the packets are forwarded by the switching chip without being filtered by the firewall. However, if necessary, users can apply specific rules for packets within the same network by creating a "bridge interface".

Port-based Bridge

If traffic within the same network needs to be filtered by the firewall (through the CPU), users can create a port-based bridge. The system will automatically generate a VID for each port within the same network, allowing these ports to provide basic firewall functions through the same interface, also referred to as a Bridge Firewall.

Port-based bridges are less complex than zone-based bridges but are not able to have multiple ports within a VLAN similar to a zone-based bridge.

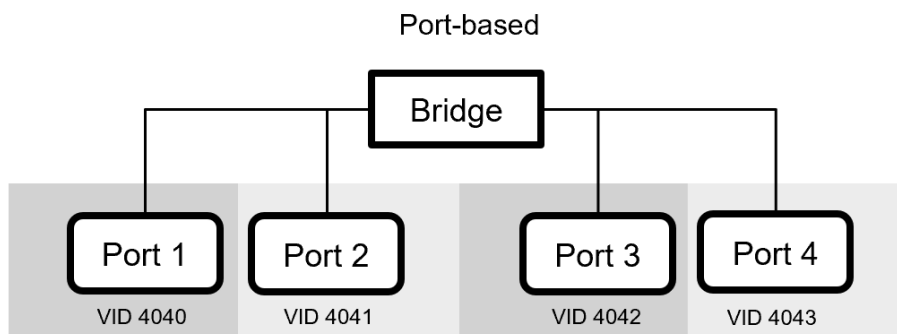

Zone-based Bridge

If traffic within the same network needs to be filtered by the firewall (through the CPU), but also needs to be switched (through chip) at the same time, users can create a zone-based bridge. Zone-based bridges allow users to combine several VLAN groups into one. As a result, zone-based bridges can have multiple ports within a VLAN, leading to a more flexible network topology compared to port-based bridges.

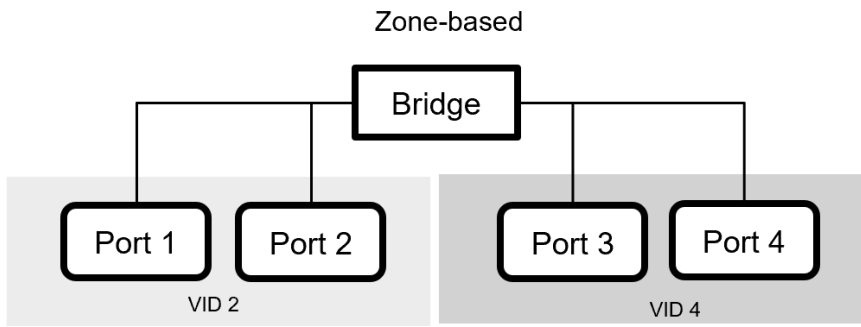

Refer to below graph for a summary of bridge traffic behavior. In scenario 1 and 2, traffic between different ports in a port-based bridge environment and traffic across different VLANs in a zone-based bridge environment are directed through CPU bridging. In scenario 3, traffic within the same VLAN is directed by the switching chip. In scenario 4, traffic across different interfaces is directed through CPU routing. Using zone-based bridges, users can have more control and flexibility to design the network topology.

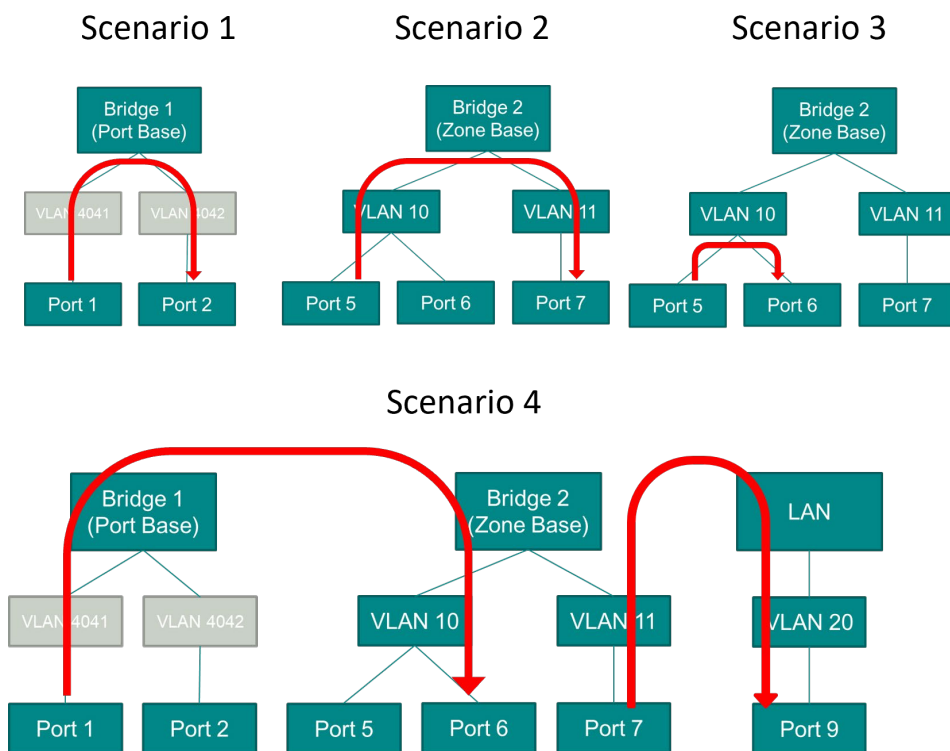

Bridge Configuration

Bridge IP Configuration

Name:

Enable:

Mode:

IP Address:

Subnet Mask:

Member Port: Port1 Port2 Port3 Port4
 Port5 Port6 Port7 Port8
 Port9 Port10 Port11 Port12
 Port13 Port14 Port15 Port16

Bridge Interface List (2/8)

| Name | Enable | Type | IP Address | Subnet Mask | Member |
|------|-------------------------------------|-----------|-----------------|---------------|-----------------------|
| LAN | <input checked="" type="checkbox"/> | Port-Base | 192.168.128.200 | 255.255.255.0 | Port3, Port7, Port11, |
| LAN2 | <input checked="" type="checkbox"/> | Port-Base | 192.168.126.200 | 255.255.255.0 | Port4, Port8, Port12, |

Bridge Configuration

Bridge IP Configuration

Name:

Enable:

Mode:

IP Address:

Subnet Mask:

Member Vlan: VID2 VID3

Bridge Interface List (1/8)

| Name | Enable | Type | IP Address | Subnet Mask | Member |
|-----------|-------------------------------------|-----------|------------|---------------|-------------|
| Integrate | <input checked="" type="checkbox"/> | Zone-Base | 1.1.1.1 | 255.255.255.0 | VID2, VID3, |

Create a Bridge Interface

Enter a name for the Bridge interface, check the Enable box, select the bridge mode, and assign an IP address/subnet mask for the interface. Select the Member VLAN port for port-based bridges or the preconfigured VLAN settings under the Layer 2 Function for zone-based bridges.

Click **Add** to add this interface.



NOTE

The maximum amount of bridge interfaces is 8.

Delete a Bridge Interface

Select the interface in the Bridge interface List and click **Delete** to delete the interface.

Modify a Bridge Interface

Select the interface in the Bridge Interface List, edit the interface attributes, and click **Modify** to apply the changes.

Apply the Bridge Interface List

After adding, deleting, modifying any Bridge interfaces, click **Apply** to update the list.

Name

| Setting | Description | Factory Default |
|--------------------|--|-----------------|
| Max. 40 characters | Enter a name for the bridge interface. | None |

Enable

| Setting | Description | Factory Default |
|----------------|---|-----------------|
| Enable/Disable | Enable or disable the bridge interface. | Disable |

Mode

| Setting | Description | Factory Default |
|------------------------|-------------------------|-----------------|
| Port-Base Zone-Base | Select the bridge mode. | Port-Base |

IP Address

| Setting | Description | Factory Default |
|------------|--|-----------------|
| IP address | Enter the IP address for the bridge interface. | 0.0.0.0 |

Subnet Mask

| Setting | Description | Factory Default |
|------------|---|-----------------|
| IP address | Enter the subnet mask for the bridge interface. | 0.0.0.0 |

Member Port (Port-based mode)

| Setting | Description | Factory Default |
|-----------------|--|-----------------|
| Select/Deselect | Check the boxes next the corresponding member ports to add these ports to this bridge interface. | None |

Member VLAN (Zone-based mode)

| Setting | Description | Factory Default |
|-----------------|--|-----------------|
| Select/Deselect | Check the boxes next the corresponding VIDs to add these VLANs to this bridge interface. | None |

DHCP

DHCP Global Setting

 **DHCP Global Setting**

DHCP Server Mode Option

Disable

Dynamic DHCP / IP-MAC Binding

IP-Port Binding

DHCP Server Syslog Option

Enable Syslog

DHCP Server Mode

| Setting | Description | Factory Default |
|-----------------------------|-----------------------------|-----------------|
| Disable | | |
| Dynamic DHCP/IP-MAC Binding | Select the DHCP Server Mode | Disabled |
| IP-Port Binding | | |

Enable Syslog

| Setting | Description | Factory Default |
|----------------|--|-----------------|
| Enable/Disable | Enable Syslog to send log message to Syslog server | Disabled |

Dynamic DHCP

The ToughNet Secure Router provides a DHCP (Dynamic Host Configuration Protocol) Server function for LAN interfaces. When configured, the ToughNet Secure Router will automatically assign an IP address to an Ethernet device from a defined IP range.

DHCP

Enable

Option 82 Circuit-ID Hexadecimal ▾

Option 82 Remote-ID Hexadecimal ▾

Pool First IP Address Pool Last IP Address

Netmask

Lease Time (min)

Default Gateway

DNS Server 1 DNS Server 2

NTP Server

TFTP Server

Bootfile Name IP ▾

Dynamic IP Pool (0/16) (Only one pool for each subnet)

| Enable | Option 82 Circuit-ID | Option 82 Remote-ID | Pool First IP Address | Pool Last IP Address | Netmask | Lease Time | Default Gateway | DNS Server 1 | DNS Server 2 | NTP Server | TFTP Server | Bootfile Name |
|--------|----------------------|---------------------|-----------------------|----------------------|---------|------------|-----------------|--------------|--------------|------------|-------------|---------------|
|--------|----------------------|---------------------|-----------------------|----------------------|---------|------------|-----------------|--------------|--------------|------------|-------------|---------------|

DHCP Server Enable/Disable

| Setting | Description | Factory Default |
|----------------|--|-----------------|
| Enable/Disable | Enable or disable the DHCP server function | Disable |

Option 82 Circuit-ID

| Setting | Description | Factory Default |
|--------------------|-----------------------------------|-----------------|
| Max. 20 characters | The name of the Circuit-ID | None |
| Hexadecimal/String | Select the type of the Circuit-ID | Hexadecimal |

Option 82 Remote-ID

| Setting | Description | Factory Default |
|--------------------|---------------------------|-----------------|
| Max. 20 characters | The name of the Remote-ID | None |

| Setting | Description | Factory Default |
|--------------------|----------------------------------|-----------------|
| Hexadecimal/String | Select the type of the Remote-ID | Hexadecimal |

Pool First IP Address

| Setting | Description | Factory Default |
|------------|---|-----------------|
| IP Address | The first IP address of the offered IP address range for DHCP clients | 0.0.0.0 |

Pool Last IP Address

| Setting | Description | Factory Default |
|------------|--|-----------------|
| IP Address | The last IP address of the offered IP address range for DHCP clients | 0.0.0.0 |

Netmask

| Setting | Description | Factory Default |
|---------|------------------------------|-----------------|
| Netmask | The netmask for DHCP clients | 0.0.0.0 |

Lease Time

| Setting | Description | Factory Default |
|----------|-----------------------------------|-----------------|
| ≥ 5 min. | The lease time of the DHCP server | None |

Default Gateway

| Setting | Description | Factory Default |
|------------|--------------------------------------|-----------------|
| IP Address | The default gateway for DHCP clients | 0.0.0.0 |

DNS Server

| Setting | Description | Factory Default |
|----------------|---------------------------------|------------------------|
| IP Address | The DNS server for DHCP clients | 0.0.0.0 |

NTP Server

| Setting | Description | Factory Default |
|----------------|---------------------------------|------------------------|
| IP Address | The NTP server for DHCP clients | 0.0.0.0 |

TFTP Server

| Setting | Description | Factory Default |
|----------------|----------------------------------|------------------------|
| IP Address | The TFTP server for DHCP clients | None |
| IP/Domain Name | Select the type of TFTP server | IP |

Boot File Name

| Setting | Description | Factory Default |
|--------------------|-----------------------|------------------------|
| Max. 20 characters | The name of boot file | None |

Clickable Buttons

Add

Use the **Add** button to input a new DHCP list.

Delete

Use the **Delete** button to delete a Dynamic DHCP list. Click on a list to select it (the background color of the device will change to blue) and then click the **Delete** button.

Modify

To modify the information for a particular list, click on a list to select it (the background color of the device will change to blue), modify the information as needed using the check boxes and text input boxes near the top of the browser window, and then click **Modify**.

Apply

Remember to click **Apply** after adding/deleting/modifying the Static DHCP list.



NOTE

1. The DHCP Server is only available for LAN interfaces.
2. The Pool First/Last IP Address must be in the same Subnet on the LAN.

DHCP Leases

The Dynamic DHCP Leases shows the DHCP clients with Name, MAC Address, IP Address, and Time Left.

DHCP Leases

| Name | MAC Address | IP Address | Time Left |
|------|-------------|------------|-----------|
|------|-------------|------------|-----------|

IP-MAC Binding

Use the IP-MAC Binding list to ensure that devices connected to the ToughNet Secure Router always use the same IP address. The static DHCP list matches IP addresses to MAC addresses.

IP-MAC Binding

Enable
 Name:
 MAC Address:
 Static IP:
 Netmask:
 Lease Time: (minutes)
 Default Gateway:
 DNS Server 1: DNS Server 2:
 NTP Server:
 TFTP Server:
 Bootfile Name:

Static IP Pool (3/256)

| Enable | Name | MAC Address | Static IP | Netmask | Lease Time | Default Gateway | DNS Server 1 | DNS Server 2 | NTP Server | TFTP Server | Bootfile Name |
|-------------------------------------|-----------|-------------------|-----------------|---------------|------------|-----------------|-----------------|-----------------|-----------------|-----------------|------------------|
| <input checked="" type="checkbox"/> | Device-01 | 00:90:ad:00:aa:01 | 192.168.127.101 | 255.255.255.0 | 60 | 192.168.127.254 | 192.168.127.201 | 192.168.127.202 | 192.168.127.203 | 192.168.127.204 | bootfile_name-01 |
| <input checked="" type="checkbox"/> | Device-02 | 00:90:ad:00:aa:02 | 192.168.127.102 | 255.255.255.0 | 60 | 192.168.127.254 | 192.168.127.201 | 192.168.127.202 | 192.168.127.203 | 192.168.127.204 | bootfile_name-02 |
| <input checked="" type="checkbox"/> | Device-03 | 00:90:ad:00:aa:03 | 192.168.127.103 | 255.255.255.0 | 60 | 192.168.127.254 | 192.168.127.201 | 192.168.127.202 | 192.168.127.203 | 192.168.127.204 | bootfile_name-03 |

In the above example, a device named "Device-01" was added to the Static DHCP list, with a static IP address set to 192.168.127.101 and MAC address set to 00:09:ad:00:aa:01. When a device with a MAC address of 00:09:ad:00:aa:01 is connected to the ToughNet Secure Router, the ToughNet Secure Router will offer the IP address 192.168.127.101 to this device.

IP-MAC Binding Enable/Disable

| Setting | Description | Factory Default |
|----------------|---|-----------------|
| Enable/Disable | Enable or disable the DHCP server function. | Disable |

Name

| Setting | Description | Factory Default |
|--------------------|---|-----------------|
| Max. 10 characters | The name of the selected device in IP-MAC Binding list. | None |

MAC Address

| Setting | Description | Factory Default |
|-------------|--|-----------------|
| MAC Address | The MAC address of the selected device | None |

Static IP

| Setting | Description | Factory Default |
|------------|---------------------------------------|-----------------|
| IP Address | The IP address of the selected device | 0.0.0.0 |

Netmask

| Setting | Description | Factory Default |
|---------|-------------------------------------|-----------------|
| Netmask | The netmask for the selected device | 0.0.0.0 |

Lease Time

| Setting | Description | Factory Default |
|---------|---------------------------------------|-----------------|
| ≥ 5min. | The lease time of the selected device | None |

Default Gateway

| Setting | Description | Factory Default |
|------------|---|-----------------|
| IP Address | The default gateway for the selected device | 0.0.0.0 |

DNS Server

| Setting | Description | Factory Default |
|----------------|--|------------------------|
| IP Address | The DNS server for the selected device | 0.0.0.0 |

NTP Server

| Setting | Description | Factory Default |
|----------------|--|------------------------|
| IP Address | The NTP server for the selected device | 0.0.0.0 |

TFTP Server

| Setting | Description | Factory Default |
|-----------------|---|------------------------|
| IP Address | The TFTP server for the selected device | None |
| IP/ Domain Name | Select type of TFTP server description | IP |

Bootfile Name

| Setting | Description | Factory Default |
|--------------------|-----------------------|------------------------|
| Max. 20 characters | The name of boot file | None |

Clickable Buttons

Add

Use **Add** to input a new DHCP list. The Name, Static IP, and MAC address must be different from any existing list.

Delete

Use the **Delete** button to delete a Static DHCP list. Click on a list to select it (the background color of the device will change to blue) and then click **Delete**.

Modify

To modify the information for a particular list, click on a list to select it (the background color of the device will change to blue), modify the information as needed using the check boxes and text input boxes near the top of the browser window, and then click **Modify**.

Apply

After adding/deleting/modifying Static DHCP list, be sure to click **Apply**.

IP-Port Binding

IP-Port Binding

Enable
 Port
 Static IP
 Netmask
 Lease Time (minutes)
 Default Gateway
 DNS Server 1 DNS Server 2
 NTP Server
 TFTP Server
 Bootfile Name
 LLDP Validation

Static IP Pool (0/16)

| Enable | Port | Static IP | Netmask | Lease Time | Default Gateway | DNS Server 1 | DNS Server 2 | NTP Server | TFTP Server | Bootfile Name |
|--------|------|-----------|---------|------------|-----------------|--------------|--------------|------------|-------------|---------------|
|--------|------|-----------|---------|------------|-----------------|--------------|--------------|------------|-------------|---------------|

IP-Port Binding Enable/Disable

| Setting | Description | Factory Default |
|-----------------|--|-----------------|
| Enable/ Disable | Enable or disable IP-Port Binding function | Disable |

Port

| Setting | Description | Factory Default |
|-------------|---|-----------------|
| Port Number | Set the desired port of the connected devices | None |

Static IP

| Setting | Description | Factory Default |
|------------|--|-----------------|
| IP Address | The IP address of the connected device | 0.0.0.0 |

Netmask

| Setting | Description | Factory Default |
|---------|--------------------------------------|-----------------|
| Netmask | The netmask for the connected device | 0.0.0.0 |

Lease Time

| Setting | Description | Factory Default |
|---------|--|-----------------|
| ≥ 5min. | The lease time of the connected device | None |

Default Gateway

| Setting | Description | Factory Default |
|------------|--|-----------------|
| IP Address | The default gateway for the connected device | 0.0.0.0 |

DNS Server

| Setting | Description | Factory Default |
|------------|---|-----------------|
| IP Address | The DNS server for the connected device | 0.0.0.0 |

NTP Server

| Setting | Description | Factory Default |
|------------|---|-----------------|
| IP Address | The NTP server for the connected device | 0.0.0.0 |

TFTP Server

| Setting | Description | Factory Default |
|-----------------|--|-----------------|
| IP Address | The TFTP server for the connected device | None |
| IP/ Domain Name | Select type of TFTP server description | IP |

Bootfile Name

| Setting | Description | Factory Default |
|--------------------|-----------------------|-----------------|
| Max. 20 characters | The name of boot file | None |

LLDP validation

| Setting | Description | Factory Default |
|----------------|-----------------------------------|------------------------|
| Enable/Disable | Enable or disable LLDP validation | Disable |

Clickable Buttons

Add

Use the **Add** button to input a new IP-Port Binding list.

Delete

Use the **Delete** button to delete a IP-Port Binding list. Click on a list to select it (the background color of the device will change to blue) and then click the **Delete** button.

Modify

To modify the information for a particular list, click on a list to select it (the background color of the device will change to blue), modify the information as needed using the check boxes and text input boxes near the top of the browser window, and then click **Modify**.

Apply

After adding/deleting/modifying IP-Port Binding list, be sure to click **Apply**.

Configuring DHCP Relay Agent

DHCP Relay Agent

Server IP Address

Interface

1st Server

2nd Server

3rd Server

4th Server

DHCP Option 82

Enable Option 82

Type

Value

Display

DHCP Function Table

| Port | Circuit-ID | Option 82 |
|------|------------|---------------------------------|
| 1 | 01000101 | <input type="checkbox"/> Enable |
| 2 | 01000102 | <input type="checkbox"/> Enable |
| 3 | 01000103 | <input type="checkbox"/> Enable |
| 4 | 01000104 | <input type="checkbox"/> Enable |
| 5 | 01000105 | <input type="checkbox"/> Enable |
| 6 | 01000106 | <input type="checkbox"/> Enable |
| 7 | 01000107 | <input type="checkbox"/> Enable |
| 8 | 01000108 | <input type="checkbox"/> Enable |
| 9 | 01000109 | <input type="checkbox"/> Enable |
| 10 | 0100010a | <input type="checkbox"/> Enable |
| 11 | 0100010b | <input type="checkbox"/> Enable |
| 12 | 0100010c | <input type="checkbox"/> Enable |
| 13 | 0100010d | <input type="checkbox"/> Enable |
| 14 | 0100010e | <input type="checkbox"/> Enable |
| 15 | 0100010f | <input type="checkbox"/> Enable |
| 16 | 01000110 | <input type="checkbox"/> Enable |

Apply

Server IP Address

Interface

| Setting | Description | Factory Default |
|---|--|-----------------|
| Dependent on previously configured interface settings | Select a previously created interface. | N/A |

1st Server

| Setting | Description | Factory Default |
|------------------------------------|--|------------------------|
| IP address for the 1st DHCP server | Assigns the IP address of the 1st DHCP server that the switch tries to access. | None |

2nd Server

| Setting | Description | Factory Default |
|------------------------------------|--|------------------------|
| IP address for the 2nd DHCP server | Assigns the IP address of the 2nd DHCP server that the switch tries to access. | None |

3rd Server

| Setting | Description | Factory Default |
|------------------------------------|--|------------------------|
| IP address for the 3rd DHCP server | Assigns the IP address of the 3rd DHCP server that the switch tries to access. | None |

4th Server

| Setting | Description | Factory Default |
|------------------------------------|--|------------------------|
| IP address for the 4th DHCP server | Assigns the IP address of the 4th DHCP server that the switch tries to access. | None |

DHCP Option 82

Enable Option 82

| Setting | Description | Factory Default |
|----------------|--|------------------------|
| Enable/Disable | Enable or disable the DHCP Option 82 function. | Disable |

Type

| Setting | Description | Factory Default |
|----------------|--|------------------------|
| Interface | Uses the switch's interface IP address as the remote ID sub. | IP |

| Setting | Description | Factory Default |
|-----------|---|-----------------|
| MAC | Uses the switch's MAC address as the remote ID sub. | IP |
| Client-ID | Uses a combination of the switch's MAC address and IP address as the remote ID sub. | IP |
| Other | Uses the user-designated ID sub. | IP |

Value

| Setting | Description | Factory Default |
|-----------|---|-----------------|
| Read-only | Displays the value that was set. Complete this field if type is set to Other. | N/A |

Display

| Setting | Description | Factory Default |
|-----------|---|-----------------|
| Read-only | The actual value configured in the DHCP server. | 00000000 |

DHCP Function Table

Enable

| Setting | Description | Factory Default |
|----------------|--|-----------------|
| Enable/Disable | Enable or disable the DHCP Option 82 function for this port. | Disable |

SNMP

The ToughNet Secure Router supports SNMP V1/V2c/V3. SNMP V1 and SNMP V2c use a community string match for authentication, which means that SNMP servers access all objects with read-only permissions using the community string public (default value). SNMP V3, which requires that the user selects an authentication level of MD5 or SHA, is the most secure protocol. You can also enable data encryption to enhance data security. SNMP security modes and security levels supported by the ToughNet Secure Router are shown in the following table. Select the security mode and level that will be used to communicate between the SNMP agent and manager.

| Protocol Version | UI Setting | Authentication Type | Data Encryption | Method |
|------------------|------------------------|------------------------------------|---------------------|--|
| SNMP V1, V2c | V1, V2c Read Community | Community string | No | Uses a community string match for authentication |
| SNMP V3 | MD5 or SHA | Authentication based on MD5 or SHA | No | Provides authentication based on HMAC-MD5, or HMAC-SHA algorithms. 8-character passwords are the minimum requirement for authentication. |
| | MD5 or SHA | Authentication based on MD5 or SHA | Data encryption key | Provides authentication based on HMAC-MD5 or HMAC-SHA algorithms, and data encryption key. 8-character passwords and a data encryption key are the minimum requirements for authentication and encryption. |

These parameters are configured on the SNMP page. A more detailed explanation of each parameter is given below.

SNMP

System Information

SNMP Versions: Disable

Admin Auth. Type: No-Auth

Enable Admin Data Encryption Data Encryption Key:

User Auth. Type: No-Auth

Enable User Data Encryption Data Encryption Key:

Community Strings

Community 1: public Access Control 1: Read/Write

Community 2: private Access Control 2: Read/Write

Trap Community: trap Trap Mode: Trap V1

(Note : Inform V2c mode will retry 3 times, and the retry period is 10s)

Trap Servers

IP Address 1: 0.0.0.0

IP Address 2: 0.0.0.0

IP Address 3: 0.0.0.0

Apply

SNMP Versions

| Setting | Description | Factory Default |
|--|--|-----------------|
| Disable V1, V2c, V3, or V1, V2c, or V3 only | Select the SNMP protocol version used to manage the secure router. | Disable |

Auth. Type

| Setting | Description | Factory Default |
|---------|---|-----------------|
| MD5 | Provides authentication based on the HMAC-MD5 algorithms. 8-character passwords are the minimum requirement for authentication. | MD5 |
| SHA | Provides authentication based on the HMAC-SHA algorithms. 8-character passwords are the minimum requirement for authentication. | |
| No-Auth | Provides no authentication | |

Data Encryption Enable/Disable

| Setting | Description | Factory Default |
|----------------|---------------------------------------|-----------------|
| Enable/Disable | Enable of disable the data encryption | Disable |

Data Encryption Key

| Setting | Description | Factory Default |
|--------------------|--|-----------------|
| Max. 30 Characters | 8-character data encryption key is the minimum requirement for data encryption | None |

Community Name

| Setting | Description | Factory Default |
|--------------------|---|-----------------|
| Max. 30 Characters | Use a community string match for authentication | Public |

Access Control

| Setting | Description | Factory Default |
|-----------------------------|---|-----------------|
| Read/Write | Access control type after matching the community string | Read/Write |
| Read only (Public MIB only) | | |
| No Access | | |

Trap Server IP Address

| Setting | Description | Factory Default |
|------------|---|-----------------|
| IP Address | Enter the IP address of the Trap Server used by your network. | 0.0.0.0. |

DNS Server

The DNS is a protocol which turns a user-friendly domain name such as "moxa.com" into an IP address like 192.168.25.150 that computers use to identify each other on the network. A simple illustration of the DNS operation is shown below:

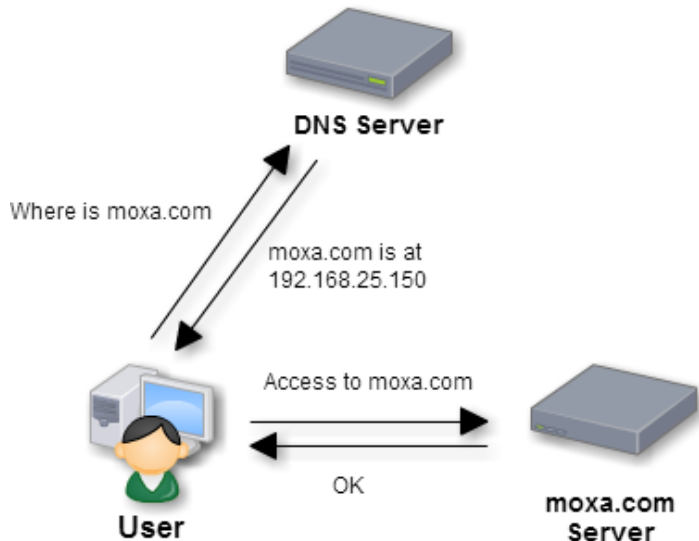

From the Global Settings screen, you can configure basic DNS server functions such as the server type and service interfaces. If **Recursive** mode is selected, a built-in root hints file will be applied by default. However, user can still configure up to 2 additional user-defined root servers. If there is a conflict between the FQDNs of user-defined servers and those in the root hints file, user-defined servers have higher priority and will be adopted first.

DNS Global Setting

DNS Global Setting

Enable

Port

Server Type Recursive Forwarder Authoritative

User-Defined DNS Root Server

Name Server FQDN 1

Name Server IP 1

Name Server FQDN 2

Name Server IP 2

Interface Settings

Enable

Interface

Service Interface (0/16)

| Enable | Interface | VID | IP Address |
|--------------------------------------|-----------|-----|------------|
| <input type="button" value="Apply"/> | | | |

Enable DNS Server

| Setting | Description | Factory Default |
|----------------|----------------------------------|-----------------|
| Enable/Disable | Enable or disable the DNS server | Disabled |

Port

| Setting | Description | Factory Default |
|-------------|--|-----------------|
| Port number | Specify the DNS server port, ranging between 1 and 65535 | 53 |

Server Type

| Setting | Description | Factory Default |
|-----------------------------------|---|-----------------|
| Recursive/Forwarder/Authoritative | Select the DNS server type Recursive: Allow DNS server to contact root server directly for recursive queries Forwarder: Set the DNS server to forward all queries to a global forwarder Authoritative: The DNS server will only process queries in the local authoritative zone | Recursive |

User-defined DNS Root Server – Recursive Mode

Name Server Full Qualified Domain Name (FQDN)

| Setting | Description | Factory Default |
|-----------------|----------------------------|-----------------|
| DNS Domain Name | Define the DNS server FQDN | None |

Name Server IP

| Setting | Description | Factory Default |
|----------------|---|-----------------|
| Name Server IP | Specify the IP address of the DNS server FQDN | 0.0.0.0 |

Interface Settings

Enable Interface

| Setting | Description | Factory Default |
|----------------|--|-----------------|
| Enable/Disable | Enable or disable the DNS server interface | Enabled |

Interface

| Setting | Description | Factory Default |
|---------------|----------------------------------|-----------------|
| LAN Interface | Select the DNS service interface | LAN |

Clickable Buttons

Add

Click the **Add** button to add a new interface.

Delete

Click on a list to select it, the background color of the interface will change to blue, then click the **Delete** button.

Modify

Click on an interface to select it, the background color of the interface will change to blue, then click **Modify** to change the information of the selected interface.

Apply

Click **Apply** after adding, deleting, or modifying an interface to apply the changes.

DNS Global Setting

Enable

Port

Server Type Recursive Forwarder Authoritative

Global Forwarders

Name Server IP 1

Name Server IP 2

Interface Settings

Enable

Interface

Service Interface (0/16)

| Enable | Interface | VID | IP Address |
|--------|-----------|-----|------------|
|--------|-----------|-----|------------|

User-defined DNS Root Server – Forwarder Mode

Name Server IP

| Setting | Description | Factory Default |
|----------------|--|-----------------|
| Name Server IP | Specify the IP address of the DNS server | 0.0.0.0 |

Interface Settings

Enable Interface

| Setting | Description | Factory Default |
|----------------|--|-----------------|
| Enable/Disable | Enable or disable the DNS server interface | Enabled |

Interface

| Setting | Description | Factory Default |
|---------------|----------------------------------|-----------------|
| LAN Interface | Select the DNS service interface | LAN |

Clickable Buttons

Add

Click the **Add** button to add a new interface.

Delete

Click on a list to select it, the background color of the interface will change to blue, then click the **Delete** button.

Modify

Click on an interface to select it, the background color of the interface will change to blue, then click **Modify** to change the information of the selected interface.

Apply

Click **Apply** after adding, deleting, or modifying an interface to apply the changes.

DNS Global Setting

Enable

Port

Server Type Recursive Forwarder Authoritative

Interface Settings

Enable

Interface

Add **Delete** **Modify**

Service Interface (0/16)

| Enable | Interface | VID | IP Address |
|--------|-----------|-----|------------|
| | | | |

Apply

User-defined DNS Root Server – Authoritative Mode

Interface Settings

Enable Interface

| Setting | Description | Factory Default |
|----------------|--|-----------------|
| Enable/Disable | Enable or disable the DNS server interface | Enabled |

Interface

| Setting | Description | Factory Default |
|---------------|----------------------------------|-----------------|
| LAN Interface | Select the DNS service interface | LAN |

Clickable Buttons

Add

Click the **Add** button to add a new interface.

Delete

Click on a list to select it, the background color of the interface will change to blue, then click the **Delete** button.

Modify

Click on an interface to select it, the background color of the interface will change to blue, then click **Modify** to change the information of the selected interface.

Apply

Click **Apply** after adding, deleting, or modifying an interface to apply the changes.

DNS Zone Setting

The DNS server can support up to 5 local authoritative zones. Each zone supports up to 5 Name Server (NS) Resource Records and up to 40 Address (A) Resource Records (RR).

DNS Zone Setting

Zone Index 1 ▼

Enable

Domain Name

Resource Records Setting

Type NS ▼

Subdomain

TTL (sec) 86400

Server Name

Server IP 0.0.0.0

Add
Delete
Modify

NS Records (0/5)

| Domain Name | TTL | Name | IP |
|-------------|-----|------|----|
| | | | |

A Records (0/40)

| Host Name | TTL | IP | Reverse Lookup |
|-----------|-----|----|----------------|
| | | | |

Apply

Zone Index

| Setting | Description | Factory Default |
|--------------|--|-----------------|
| Index Number | Select the zone index, ranging from 1 to 5 | 1 |

Enable

| Setting | Description | Factory Default |
|----------------|--------------------------------|-----------------|
| Enable/Disable | Enable or disable the DNS zone | Disabled |

Domain Name

| Setting | Description | Factory Default |
|-------------|--|-----------------|
| Domain Name | Define the domain name of the DNS zone that will act as the local authoritative zone up to 63 characters in length | None |

Resource Records Setting

Type

| Setting | Description | Factory Default |
|-------------|---|-----------------|
| Record Type | Select the Resource Records type: Address (A) or Name Server (NS) | NS |

Subdomain

| Setting | Description | Factory Default |
|-------------|--|-----------------|
| Domain name | Define the subdomain of the Name Server (NS) up to 63 characters in length | None |

TTL (sec)

| Setting | Description | Factory Default |
|-------------|--|-----------------|
| Time period | Specify the Time to live (TTL) period in seconds | 86400 |

Server Name/Host name

| Setting | Description | Factory Default |
|-----------------------|--|-----------------|
| Server Name/Host Name | Define the DNS server name and host name up to 63 characters in length | None |

Server IP

| Setting | Description | Factory Default |
|------------|--|-----------------|
| IP Address | Specify the IP address of the DNS server | 0.0.0.0 |

Reverse Lookup

| Setting | Description | Factory Default |
|----------------|---|-----------------|
| Enable/Disable | Enable or disable Reverse Lookup if the record type is set to Address (A) | Enabled |

DNS Zone Forwarding Setting

DNS zone forwarding forwards DNS queries of a non-authoritative zone to up to two specified DNS servers. It is not possible to configure an authoritative zone of the local DNS server as the destination zone.

DNS Zone Forwarding

Enable

Domain Name

Name Server 1 IP

Name Server 1 Port

Name Server 2 IP

Name Server 2 Port

Zone Forwarding List (0/5)

| Enable | Domain Name | Name Server 1 | | Name Server 2 | |
|--------|-------------|---------------|------|---------------|------|
| | | IP | Port | IP | Port |

Enable Zone Forwarding

| Setting | Description | Factory Default |
|----------------|-----------------------------------|-----------------|
| Enable/Disable | Enable or disable zone forwarding | Disabled |

Domain name

| Setting | Description | Factory Default |
|-------------|--|-----------------|
| Domain Name | Specify the domain name of the DNS zone where the DNS requests will be forwarded to up 63 characters in length | None |

Name Server IP

| Setting | Description | Factory Default |
|------------|---|-----------------|
| IP Address | Specify the IP address of the name server | 0.0.0.0 |

Name Server Port

| Setting | Description | Factory Default |
|-------------|-------------------------------------|-----------------|
| Port Number | Specify the port of the name server | 53 |

DNS ACL Setting

The DNS access control list (ACL) determines if client subnets can send queries to the DNS server by either accepting or denying the client subnet. If no ACL rules are specified, the default policy is set to deny request from all subnets except the subnet of the service interfaces.

DNS ACL setting

Enable

Client Subnet / (255.255.255.0)

Action

ACL Rule List (0/20)

| Enable | Client Subnet | Action |
|--------|---------------|--------|
|--------|---------------|--------|

Enable DNS ACL

| Setting | Description | Factory Default |
|-------------|---|-----------------|
| Domain Name | Enable or disable the DNS access control list | None |

Client Subnet

| Setting | Description | Factory Default |
|-------------------|---|-----------------|
| IP Address/Subnet | Specify the IP address and subnet mask of the client subnet | 0.0.0.0/24 |

Action

| Setting | Description | Factory Default |
|---------|--|-----------------|
| Policy | Choose to allow or deny DNS queries coming from the specified subnet | Accept |

DNS Security Setting

From the DNS security settings screen, you can import, export, or delete trust anchors files. A default trust anchor file to the root DNS server is embedded on the local DNS server.

Enable DNS Security

| Setting | Description | Factory Default |
|----------------|--------------------------------|-----------------|
| Enable/Disable | Enable or disable DNS security | Disabled |

Ignore Checking Disabled (CD) Flag

| Setting | Description | Factory Default |
|----------------|---------------------------|-----------------|
| Enable/Disable | Enable or disable CD Flag | Disabled |

Trust Anchor

Browse/Import

Click **Browser** to select a Trust Anchor file on the ToughNet Secure Router and click **Import**. The DNS Server will automatically update the Trust Anchor.

Delete

Click **Delete** to remove the selected Trust Anchor.

Export

Click **Export** to export the selected Trust Anchor

Insecure Domain Exception List

Enable Insecure Domain Exception

| Setting | Description | Factory Default |
|----------------|---|-----------------|
| Enable/Disable | Enable or disable Insecure Domain Exception | Disabled |

Domain Name

| Setting | Description | Factory Default |
|-------------|---|-----------------|
| Domain Name | Define the domain name of the insecure list up to 63 characters in length | None |

DNS Root Hints

The DNS root hints define the authoritative name servers that serve the DNS root zone, commonly known as the root servers. These form a network of hundreds of servers in different countries around the world.

|  | | |
|---|----------------------|----------------|
| Index | DNS Root Server FQDN | IP Address |
| 1 | A.ROOT-SERVERS.NET | 198.41.0.4 |
| 2 | B.ROOT-SERVERS.NET | 199.9.14.201 |
| 3 | C.ROOT-SERVERS.NET | 192.33.4.12 |
| 4 | D.ROOT-SERVERS.NET | 199.7.91.13 |
| 5 | E.ROOT-SERVERS.NET | 192.203.230.10 |
| 6 | F.ROOT-SERVERS.NET | 192.5.5.241 |
| 7 | G.ROOT-SERVERS.NET | 192.112.36.4 |
| 8 | H.ROOT-SERVERS.NET | 198.97.190.53 |
| 9 | I.ROOT-SERVERS.NET | 192.36.148.17 |
| 10 | J.ROOT-SERVERS.NET | 192.58.128.30 |
| 11 | K.ROOT-SERVERS.NET | 193.0.14.129 |
| 12 | L.ROOT-SERVERS.NET | 199.7.83.42 |
| 13 | M.ROOT-SERVERS.NET | 202.12.27.33 |

Monitor

Statistics

Users can monitor the data transmission activity of all the ToughNet Secure Router ports from two perspectives, **Bandwidth Utilization** and **Packet Counter**. The graph displays data transmission activity by showing Utilization/Sec or Packet/Sec (i.e., packets per second, or pps) versus Min:Sec. (Minutes: Seconds). The graph is updated every 5 seconds, allowing the user to analyze data transmission activity in real-time.

Bandwidth Utilization

In **Bandwidth Utilization** mode, users can monitor total bandwidth in each interface (**IP Interface**), each port or port group (**Ports**). In addition to display type, users can configure which packet flow is monitored, **TX Packets**, **RX Packets** or both (**TX/RX**). **TX Packets** are packets sent out from the ToughNet Secure Router, and **RX Packets** are packets received from connected devices.

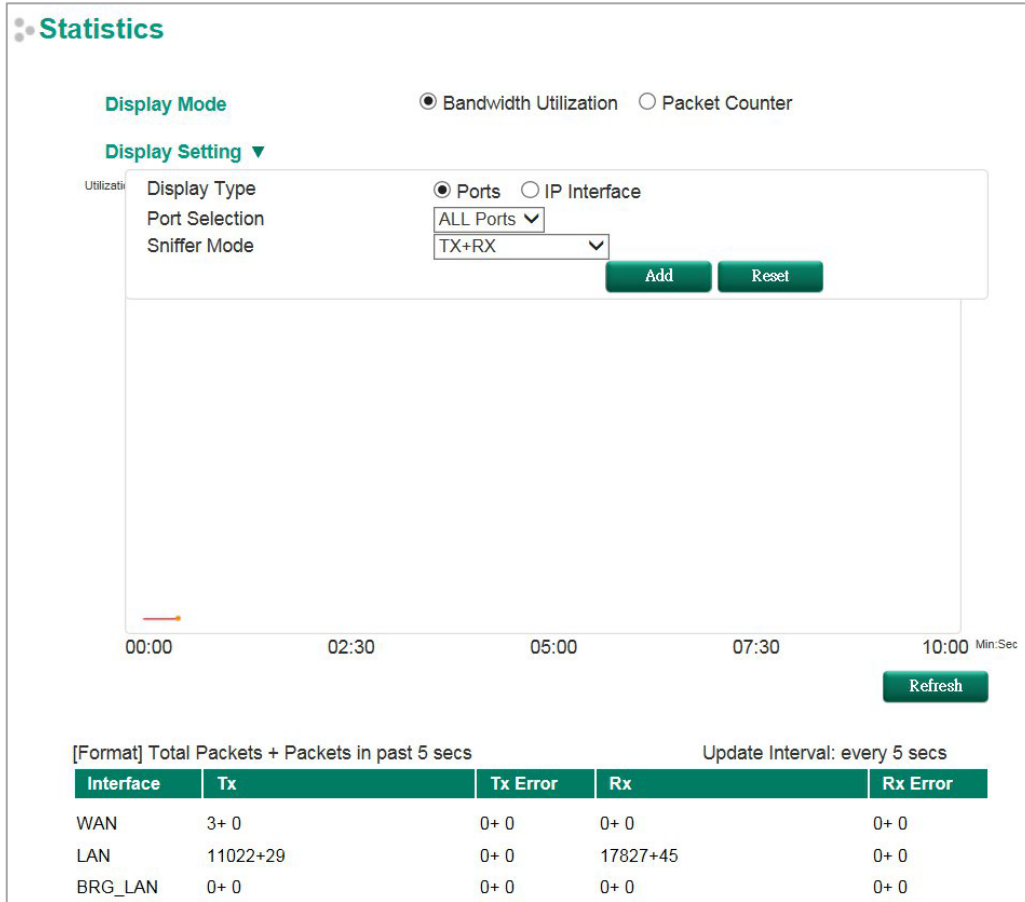

Display Mode

| Setting | Description | Factory Default |
|--|--|-----------------|
| Bandwidth Utilization/ Packet Counter | Graph display traffic bandwidth/Graph display total packet amount per second | Packet Counter |

Display Setting

Display Type

| Setting | Description | Factory Default |
|----------------------------------|---|-----------------|
| Port (only supported in EDR-810) | Monitor total traffic per port or group port (FE Ports/ GE Ports) | IP Interface |

| Setting | Description | Factory Default |
|--------------|--|-----------------|
| IP Interface | Monitor total traffic per interface, e.g. LAN, WAN, Bridge | |

Port Selection

| Setting | Description | Factory Default |
|---|---|-----------------|
| ALL Ports/ FE Ports/ GE Ports/ Port1/ Port2/ Port3/ Port4/ Port5/ Port6/ Port7/ Port8/ PortG1/ PortG2 | Users can select which port or port group they want to monitor traffic from | ALL Ports |

Interface Selection

| Setting | Description | Factory Default |
|------------------------|---|-----------------|
| All/LAN/WAN/Bridge_LAN | Select which interface user want to monitor traffic | All |

Sniffer Mode

| Setting | Description | Factory Default |
|---------------|---------------------------------------|-----------------|
| (TX/RX)/TX/RX | Select which packet flow is monitored | TX/RX |

Packet Counter

In **Packet Counter** mode, users can monitor total packet amount per second in each interface (**IP Interface**), each port or port group (**Ports**). In addition to display type, users can configure which packet flow is monitored, **TX Packets**, **RX Packets** or both (**TX/RX**). **TX Packets** are packets sent out from the ToughNet Secure Router, and **RX Packets** are packets received from connected devices. At the same time, users can choose to monitor different packet types, e.g. unicast, broadcast, multicast and error.

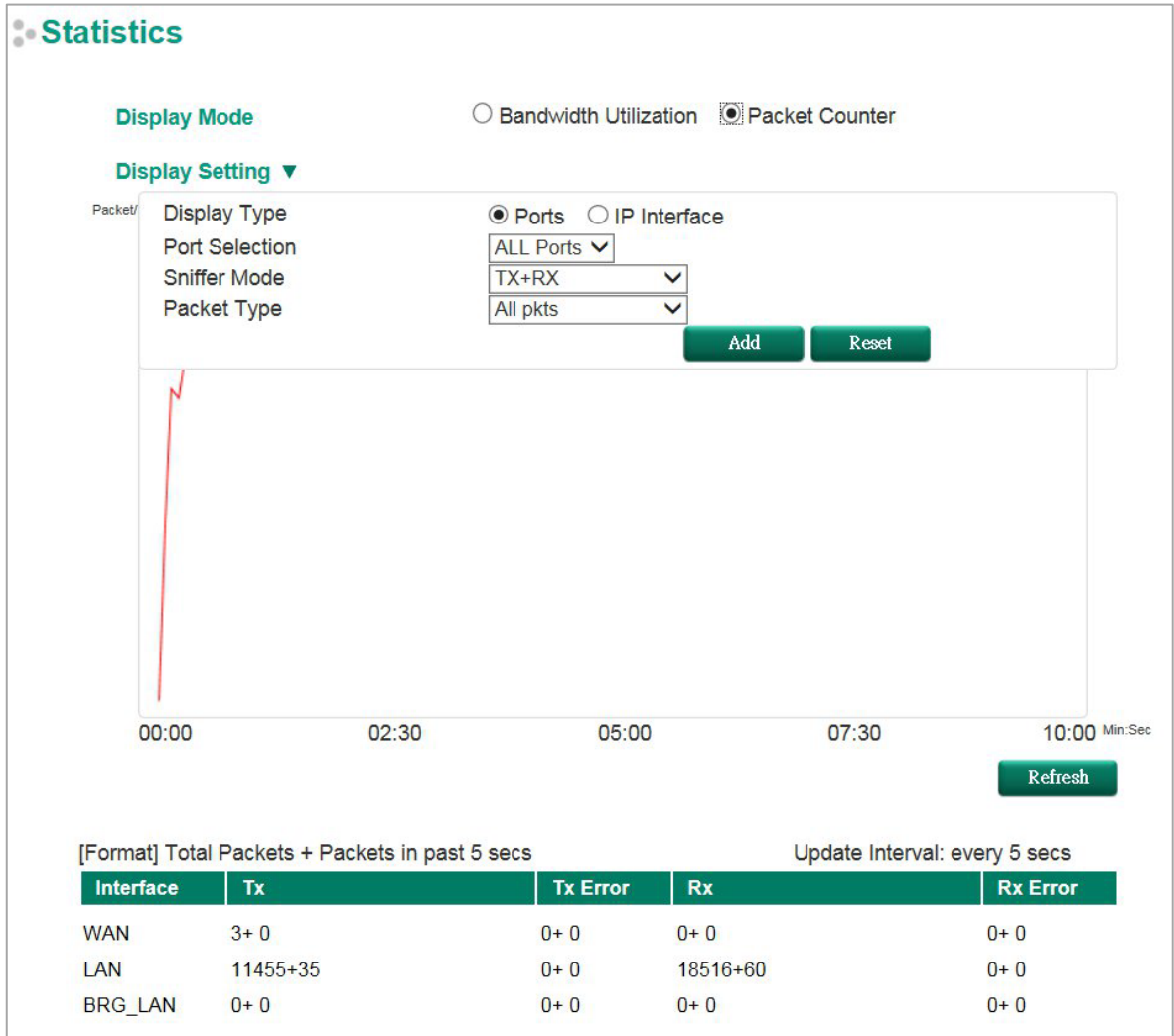

Display Mode

| Setting | Description | Factory Default |
|--|---|-----------------|
| Bandwidth Utilization/ Packet Counter | Graph display traffic bandwidth/ Graph display total packet amount per second | Packet Counter |

Display Setting

Display Type

| Setting | Description | Factory Default |
|--------------------|---|-----------------|
| Port/ IP Interface | Monitor total traffic per port or group port (FE Ports/ GE Ports)/ Monitor total traffic per interface, e.g. LAN, WAN, Bridge | IP Interface |

Port Selection

| Setting | Description | Factory Default |
|---|---|------------------------|
| ALL Ports/ FE Ports/ GE Ports/ Port1/ Port2/ Port3/ Port4/ Port5/ Port6/ Port7/ Port8/ PortG1/ PortG2 | Users can select which port or port group they want to monitor traffic from | ALL Ports |

Interface Selection

| Setting | Description | Factory Default |
|--------------------------|---|------------------------|
| All/WAN/LAN/ /Bridge_LAN | Select which interface user want to monitor traffic | All |

Sniffer Mode

| Setting | Description | Factory Default |
|----------------|---------------------------------------|------------------------|
| (TX/RX)/TX/RX | Select which packet flow is monitored | TX/RX |

Packet Type

| Setting | Description | Factory Default |
|--|---------------------------------------|------------------------|
| All/ Unicast/ Broadcast/Multicast/ Error | Select which packet type is monitored | All |

Event Log

By default, all event logs will be displayed in the table. You can filter two types of event logs, **System** and **Firewall** combined with **severity level**.

Event Log Table

All <=> <7> Debug Page 1/40

| Index | Date | Time | Functions | Severity | Event |
|-------|------------|----------|-----------|---------------|--|
| 1 | 0000/00/00 | 00:00:00 | Firewall | <4> Warning | [TCP-Without-SYN Scan] DROP PROTO=TCP, SRC_IP=1.0.0.0, SRC_IP=1.0.0.0, IN=LAN, DST_IP=0.0.0.0, DST_IP=0.0.0.0, OUT=LAN |
| 2 | 0114/11/23 | 09:26:34 | Firewall | <4> Warning | [TCP-Without-SYN Scan] DROP PROTO=TCP, SRC_IP=192.168.126.1, SRC_PORT=57768, IN=BRG, DST_IP=192.168.50.137, DST_PORT=8082, OUT=WAN |
| 3 | 2015/01/14 | 16:27:33 | System | <0> Emergency | [Link On] Port 1, Bootup:153, Startup:1d2h52m10s |
| 4 | 2015/01/14 | 16:18:59 | System | <0> Emergency | [Link Off] Port 1, Bootup:153, Startup:1d2h43m36s |
| 5 | 2015/01/14 | 16:16:39 | Firewall | <4> Warning | [TCP-Without-SYN Scan] DROP PROTO=TCP, SRC_IP=192.168.126.1, SRC_PORT=41066, IN=BRG, DST_IP=192.168.1.72, DST_PORT=445, OUT=WAN |
| 6 | 2015/01/14 | 16:16:37 | Firewall | <4> Warning | [TCP-Without-SYN Scan] DROP PROTO=TCP, SRC_IP=192.168.126.1, SRC_PORT=41066, IN=BRG, DST_IP=192.168.1.72, DST_PORT=445, OUT=WAN has repeated 6 times in past 10 seconds |
| 7 | 2015/01/14 | 16:16:27 | Firewall | <4> Warning | [TCP-Without-SYN Scan] DROP PROTO=TCP, SRC_IP=192.168.126.1, SRC_PORT=41066, IN=BRG, DST_IP=192.168.1.72, DST_PORT=445, OUT=WAN |
| 8 | 2015/01/14 | 16:03:31 | System | <0> Emergency | [Link On] Port 1, Bootup:153, Startup:1d2h28m8s |
| 9 | 2015/01/14 | 14:58:36 | System | <0> Emergency | [Link Off] Port 1, Bootup:153, Startup:1d1h23m13s |
| 10 | 2015/01/14 | 14:57:14 | Firewall | <4> Warning | [TCP-Without-SYN Scan] DROP PROTO=TCP, SRC_IP=192.168.126.1, SRC_PORT=49302, IN=BRG, DST_IP=192.168.50.137, DST_PORT=8082, OUT=WAN has repeated 5 times in past 10 seconds |

4. Routing

Unicast Routing

The ToughNet Secure Router supports two unicast routing methods: static routing and dynamic routing. Dynamic routing makes use of RIP V1/V2. You can either choose one routing method, or combine the two methods to establish your routing table. A routing entry includes the following items: the destination address, the next hop address (which is the next router along the path to the destination address), and a metric that represents the cost we have to pay to access a different network.

Static Route

You can define the routes yourself by specifying what is the next hop (or router) that the ToughNet Secure Router forwards data for a specific subnet. The settings of the Static Route will be added to the routing table and stored in the ToughNet Secure Router.

RIP (Routing Information Protocol)

RIP is a distance vector-based routing protocol that can be used to automatically build up a routing table in the ToughNet Secure Router.

The ToughNet Secure Router can efficiently update and maintain the routing table, and optimize the routing by identifying the smallest metric and most matched mask prefix.

Static Routing

The Static Routing page is used to configure the ToughNet Secure Router's static routing table.

Static Routing

Enable

Name

Destination Address

Netmask

Next Hop

Metric

Static Routing (1/512)

| Enable | Index | Name | Destination Address | Netmask | Next Hop |
|-------------------------------------|-------|-------|---------------------|---------------|---------------|
| <input checked="" type="checkbox"/> | 0 | ISP-1 | 100.10.10.1 | 255.255.255.0 | 100.10.10.254 |

Enable

Click the checkbox to enable Static Routing.

Name

The name of this Static Router list

Destination Address

You can specify the destination IP address.

Netmask

This option is used to specify the subnet mask for this IP address.

Next Hop

This option is used to specify the next router along the path to the destination.

Metric

Use this option to specify a "cost" for accessing the neighboring network.

Clickable Buttons

Add

For adding an entry to the Static Routing Table.

Delete

For removing selected entries from the Static Routing Table.

Modify

For modifying the content of a selected entry in the Static Routing Table.



NOTE

The entries in the Static Routing Table will not be added to the ToughNet Secure Router's routing table until you click the Activate button.

Routing Information Protocol (RIP)

RIP is a distance-vector routing protocol that employs the hop count as a routing metric. RIP prevents routing from looping by implementing a limit on the number of hops allowed in a path from the source to a destination.

The RIP **Setting** page is used to set up the RIP parameters.

RIP Setting

RIP State Disable ▾

Version

Version V1 V2

RIP Redistribute

Redistribute Connected Static OSPF

RIP Enable Interface

WAN

| Interface Name | IP | VID | Enable |
|----------------|-----------------|-----|--------------------------|
| LAN | 192.168.127.254 | 1 | <input type="checkbox"/> |

Apply

RIP State

| Setting | Description | Factory Default |
|----------------|--------------------------------|-----------------|
| Enable/Disable | Enable or Disable RIP protocol | Disable |

RIP Version

| Setting | Description | Factory Default |
|---------|------------------------------|-----------------|
| V1/V2 | Select RIP protocol version. | V2 |

RIP Distribution

| Setting | Description | Factory Default |
|-------------------------------------|--|-----------------|
| Connected/Static/ OSPF/Unchecked | <p>Check the checkbox to enable the Redistribute function.</p> <p>Connected: Entries learned from the directly connected interfaces will be re-distributed if this option is enabled.</p> <p>Static: Entries that are set in a static route will be re-distributed if this option is enabled.</p> <p>OSPF: Entries learned from the RIP will be re-distributed if this option is enabled.</p> | Unchecked |

RIP Enable Interface

| Setting | Description | Factory Default |
|---------|--|-----------------|
| WAN | Check the checkbox to enable RIP in the WAN interface. | Unchecked |
| LAN | Check the checkbox to enable RIP in the LAN interface. | |

Open Shortest Path First (OSPF)

Open Shortest Path First (OSPF) is a dynamic routing protocol for use on Internet Protocol (IP) networks. Specifically, it is a link-state routing protocol, and falls into the group of interior gateway protocols, operating within a single autonomous system. As a link-state routing protocol, OSPF establishes and maintains neighbor relationships in order to exchange routing updates with other routers. The neighbor relationship table is called an adjacency database in OSPF. OSPF forms neighbor relationships only with the routers directly connected to it. In order to form a neighbor relationship between two routers, the interfaces used to form the relationship must be in the same area. An interface can only belong to a single area. With OSPF enabled, the ToughNet Secure Router is able to exchange routing information with other L3 switches or routers more efficiently in a large system.

OSPF Global Settings

OSPF Global Settings

Enable OSPF

Current Router ID 192.168.99.12

Router ID

OSPF Distribution Connected Static route RIP

Apply

Each L3 switch/router has an OSPF router ID, customarily written in the dotted decimal format (e.g., 1.2.3.4) of an IP address. This ID must be established in every OSPF instance. If not explicitly configured, the default ID (0.0.0.0) will be regarded as the router ID. Since the router ID is an IP address, it does not need to be a part of any routable subnet on the network.

Enable OSPF

| Setting | Description | Factory Default |
|----------------|--|-----------------|
| Enable/Disable | This option is used to enable or disable the OSPF function globally. | Disable |

Current Router ID

| Setting | Description | Factory Default |
|-------------------|--|-----------------|
| Current Router ID | Shows the current L3 switch's Router ID. | 0.0.0.0 |

Router ID

| Setting | Description | Factory Default |
|----------------|---------------------------------|------------------------|
| Router ID | Sets the L3 switch's Router ID. | 0.0.0.0 |

OSPF Distribution

| Setting | Description | Factory Default |
|-----------|--|------------------------|
| Connected | Entries learned from the directly connected interfaces will be re-distributed if this option is enabled. | Checked (Enable) |
| Static | Entries set in a static route will be re-distributed if this option is enabled. | Unchecked (disable) |
| RIP | Entries learned from the RIP will be re-distributed if this option is enabled. | Unchecked (disable) |

OSPF Area Settings

OSPF Area Settings

Area ID:

Area Type:

Metric:

| <input type="checkbox"/> All | Area ID | Area Type | Metric |
|------------------------------|---------|-----------|--------|
| <input type="checkbox"/> | 0.0.0.0 | Normal | 0 |
| <input type="checkbox"/> | 1.1.1.1 | NSSA | 1 |

An OSPF domain is divided into areas that are labeled with 32-bit area identifiers, commonly written in the dot-decimal notation of an IPv4 address. Areas are used to divide a large network into smaller network areas. They are logical groupings of hosts and networks, including the routers connected to a particular area. Each area maintains a separate link state database whose information may be summarized towards the rest of the network by the connecting router. Thus, the topology of an area is unknown outside of the area. This reduces the amount of routing traffic between parts of an autonomous system.

Area ID

| Setting | Description | Factory Default |
|---------|---|-----------------|
| Area ID | Defines the areas that this L3 switch/router connects to. | 0.0.0.0 |

Area Type

| Setting | Description | Factory Default |
|------------------|------------------------|-----------------|
| Normal/Stub/NSSA | Defines the area type. | Normal |

Metric

| Setting | Description | Factory Default |
|---------|---------------------------|-----------------|
| Metric | Defines the metric value. | 0 |

OSPF Area Table

This is a table showing the current OSPF area table.

OSPF Interface Settings

OSPF Interface Settings

Interface Name: Auth Type:

Area ID: Auth Key:

Router Priority: MD5 Key ID:

Hello Interval (sec): Metric:

Dead Interval (sec):

| <input type="checkbox"/> | Interface Name | IP Address | Area ID | Role | Priority | Hello Interval | Dead Interval | Auth Type | Auth Key | MD5 Key ID | Metric |
|--------------------------|----------------|-------------|---------|--------|----------|----------------|---------------|-----------|----------|------------|--------|
| <input type="checkbox"/> | V200 | 172.200.1.2 | 0.0.0.0 | Backup | 1 | 10 | 40 | None | | 1 | 1 |
| <input type="checkbox"/> | V10 | 172.10.1.2 | 0.0.0.0 | DR | 1 | 10 | 40 | None | | 1 | 1 |
| <input type="checkbox"/> | V100 | 172.100.1.2 | 0.0.0.0 | Backup | 1 | 10 | 40 | None | | 1 | 1 |
| <input type="checkbox"/> | V20 | 172.20.1.2 | 0.0.0.0 | DR | 1 | 10 | 40 | None | | 1 | 1 |

Before using OSPF, you need to assign an interface for each area. Detailed information related to the interface can be defined in this section.

Interface Name

| Setting | Description | Factory Default |
|----------------|-----------------------------|-----------------|
| Interface Name | Defines the interface name. | N/A |

Area ID

| Setting | Description | Factory Default |
|---------|----------------------|-----------------|
| Area ID | Defines the Area ID. | N/A |

Router Priority

| Setting | Description | Factory Default |
|-----------------|--|------------------------|
| Router Priority | Defines the L3 switch/router's priority. | 1 |

Hello Interval (sec)

| Setting | Description | Factory Default |
|----------------|---|------------------------|
| Hello Interval | Hello packets are packets that an OSPF process sends to its OSPF neighbors to maintain connectivity with those neighbors. The hello packets are sent at a configurable interval (in seconds). The value of all hello intervals must be the same within a network. | 10 |

Dead Interval (sec)

| Setting | Description | Factory Default |
|----------------|---|------------------------|
| Dead Interval | The dead interval is also a configurable interval (in seconds), and defaults to four times the value of the hello interval. | 40 |

Auth Type

| Setting | Description | Factory Default |
|-----------------|---|------------------------|
| None/Simple/MD5 | OSPF authentication provides the flexibility of authenticating OSPF neighbors. Users can enable authentication to exchange routing update information in a secure manner. OSPF authentication can either be none, simple, or MD5. However, authentication does not need to be configured. If it is configured, all L3 switches/routers on the same segment must have the same password and authentication method. | None |

Auth Key

| Setting | Description | Factory Default |
|----------------|--|------------------------|
| Auth Key | <ul style="list-style-type: none">• pure-text password if Auth Type = Simple• encrypted password if Auth Type = MD5 | N/A |

MD5 Key ID

| Setting | Description | Factory Default |
|------------|--|-----------------|
| MD5 Key ID | MD5 authentication provides higher security than plain text authentication. This method uses the MD5 to calculate a hash value from the contents of the OSPF packet and the authentication key. This hash value is transmitted in the packet, along with a key ID. | 1 |

Metric

| Setting | Description | Factory Default |
|---------|-----------------------------------|-----------------|
| Metric | Manually set Metric/Cost of OSPF. | 1 |

OSPF Interface Table

This is a table showing the current OSPF interface table.

OSPF Virtual Link Settings

OSPF Virtual Link Settings

Transit Area ID

Neighbor Router ID

| All | Transit Area ID | Neighbor Router ID |
|-----|-----------------|--------------------|
|-----|-----------------|--------------------|

All areas in an OSPF autonomous system must be physically connected to the backbone area (Area 0.0.0.0). However, this is impossible in some cases. For those cases, users can create a virtual link to connect to the backbone through a non-backbone area and also use virtual links to connect two parts of a partitioned backbone through a non-backbone area.

Transit Area ID

| Setting | Description | Factory Default |
|-----------------|--|-----------------|
| Transit Area ID | Defines the areas that this L3 switch/router connect to. | N/A |

Neighbor Router ID

| Setting | Description | Factory Default |
|--------------------|--|-----------------|
| Neighbor Router ID | Defines the neighbor L3 switch/route's ID. | 0.0.0.0 |

OSPF Virtual Link Table

This is a table showing the current OSPF Virtual Link table.

OSPF Area Aggregation Settings

OSPF Area Aggregation Settings

Area ID

Destination Network

Subnet Mask

| Area ID | Destination Network | Subnet Mask |
|---------|---------------------|-------------|
|---------|---------------------|-------------|

Each OSPF area, which consists of a set of interconnected subnets and traffic, is handled by routers attached to two or more areas, known as Area Border Routers (ABRs). With the OSPF aggregation function, users can combine groups of routes with common addresses into a single routing table entry. The function is used to reduce the size of routing tables.

Area ID

| Setting | Description | Factory Default |
|---------|--|-----------------|
| Area ID | Select the Area ID that you want to configure. | 0.0.0.0 |

Destination Network

| Setting | Description | Factory Default |
|---------------------|--|-----------------|
| Destination Network | Fill in the network address in the area. | |

Subnet Mask

| Setting | Description | Factory Default |
|-------------------------------------|--------------------------|-------------------|
| 4(240.0.0.0) to 30(255.255.255.252) | Select the network mask. | 24(255.255.255.0) |

OSPF Area Aggregation Table

This is a table showing the current OSPF Area Aggregation table.

OSPF Neighbor Table

OSPF Neighbor Table

Page 1/1 ▾

| Index | Neighbor Router ID | Priority | State | Neighbor IP Address | Interface Name |
|-------|--------------------|----------|---------|---------------------|----------------|
| 1 | 192.168.99.14 | 1 | Full/DR | 172.100.1.4 | V100 |
| 2 | 192.168.99.13 | 1 | Full/DR | 172.200.1.3 | V200 |

OSPF Neighbor Table

This is a table showing the current OSPF Neighbor table.

OSPF LSA Table

OSPF LSA Table

Page 1/1 ▾

| Index | Area ID | LSA Type | Link State ID | Advertising Router | Aging Time | Route |
|-------|---------|----------|---------------|--------------------|------------|-------|
|-------|---------|----------|---------------|--------------------|------------|-------|

OSPF LSA Table

This is a table showing the current OSPF LSA table.

Routing Table

The **Routing Table** page shows all routing entries.

Routing Table

Page 1/1 ▾ All ▾

| Index | Type | Destination Address | Next Hop | Interface Name | Metric |
|-------|-----------|---------------------|-----------------|----------------|--------|
| 1 | connected | 192.168.127.0/24 | 192.168.127.254 | LAN | 1 |

All Routing Entry List

| Setting | Description | Factory Default |
|-----------|--------------------------------|-----------------|
| All | Show all routing entries | N/A |
| Connected | Show connected routing entries | N/A |
| Static | Show Static routing entries | N/A |

| Setting | Description | Factory Default |
|---------|-----------------------------|-----------------|
| RIP | Show RIP routing entries | N/A |
| Others | Show others routing entries | N/A |

Multicast Routing

The ToughNet Secure Router supports Static Multicast Route, Distance Vector Multicast Route Protocol (DVMRP), and Protocol Independent Multicast Sparse Mode (PIM-SM). You can define the routes yourself by specifying the inbound and outbound interfaces that the ToughNet Secure Router forwards Multicast streams to.

Global Setting

Multicast Routing Mode

Disable
 Static Multicast Route
 DVMRP
 PIM-SM

Apply

Multicast Routing Mode

| Setting | Description | Factory Default |
|---|--|-----------------|
| Disable/Static Multicast Route/DVMRP/PIM-SM | Disable Multicast routing mode or enable a specific Multicast routing protocol | Disable |

Static Multicast

Static Multicast Route

Enable

Group Address

Source Address Specify Source ▼

Inbound interface WAN ▼

Outbound interface(s) WAN LAN1 LAN2

Add
Delete
Modify
Apply

Static Multicast Routes (0/256)

| Enable | Group Address | Source Address | Inbound interface | Outbound interface(s) |
|--------|---------------|----------------|-------------------|-----------------------|
|--------|---------------|----------------|-------------------|-----------------------|

Static Multicast Route Enable/Disable

| Setting | Description | Factory Default |
|----------------|---|-----------------|
| Enable/Disable | Enable or disable the specific Static Multicast Route | Disable |

Group Address

| Setting | Description | Factory Default |
|------------|---|-----------------|
| IP Address | The IP address of the Multicast Group Address | 0.0.0.0 |

Source Address

| Setting | Description | Factory Default |
|----------------|---|-------------------------|
| IP Address/Any | The IP address of the Multicast Source Address. The specific IP address can be set or choose ANY for any IP address | Specify Source: 0.0.0.0 |

Inbound Interface

| Setting | Description | Factory Default |
|------------|--|-----------------------|
| Interfaces | Select the inbound interface of the Multicast stream | One of the interfaces |

Outbound Interface

| Setting | Description | Factory Default |
|------------|---|-----------------------|
| Interfaces | Select the outbound interface of the Multicast stream | One of the interfaces |

Clickable Buttons

Add

Use the **Add** button to input a new Multicast Routing list.

Delete

Use the **Delete** button to delete a Multicast Routing list. Click on a list to select it (the background color of the device will change to blue) and then click the **Delete** button.

Modify

To modify the information for a particular list, click on a list to select it (the background color of the device will change to blue), modify the information as needed using the check boxes and text input boxes near the top of the browser window, and then click **Modify**.

Apply

Remember to click **Apply** after adding/deleting/modifying the Multicast Routing list.

Distance Vector Multicast Routing Protocol (DVMRP)

Distance Vector Multicast Routing Protocol (DVMRP) is used to build multicast delivery trees on a network. When a Layer 3 switch receives a multicast packet, DVMRP provides a routing table for the relevant multicast group, and include distance information on the number of devices between the router and the packet destination. The multicast packet will then be forwarded through the ToughNet Secure Router interface specified in the multicast routing table.

DVMRP Settings

This page is used to set up the DVMRP table for the ToughNet Secure Router

DVMRP Settings

Enable DVMRP

| Enable | Interface Name | IP | VID |
|--------------------------|----------------|-------------|-----|
| <input type="checkbox"/> | V100 | 172.100.1.2 | 100 |
| <input type="checkbox"/> | V200 | 172.200.1.2 | 200 |
| <input type="checkbox"/> | V10 | 172.10.1.2 | 10 |
| <input type="checkbox"/> | V20 | 172.20.1.2 | 20 |

Enable DVMRP

| Setting | Description | Factory Default |
|----------------|----------------------------------|-----------------|
| Enable/Disable | Enable or disable DVMRP globally | Disable |

Enable (individual)

| Setting | Description | Factory Default |
|----------------|---|-----------------|
| Enable/Disable | Enable or disable DVMRP by the selected interface | Disable |



NOTE

Only one multicast routing protocol can be enabled. DVMRP and PIM-SM can NOT be enabled simultaneously.

DVMRP Routing Table

DVMRP Routing Table

▼

| Index | Origin | Next Hop | Interface Name | VID | Cost | Expire Time |
|-------|--------|----------|----------------|-----|------|-------------|
|-------|--------|----------|----------------|-----|------|-------------|

DVMRP Routing Table

This is a table showing the current DVMRP Routing table.

DVMRP Neighbor Table

DVMRP Routing List

▼

| Index | Neighbor IP | Interface Name | VID | Expire Time | Hold Time |
|-------|-------------|----------------|-----|-------------|-----------|
|-------|-------------|----------------|-----|-------------|-----------|

DVMRP Neighbor Table

This is a table showing the current DVMRP Neighbor table.

Protocol Independent Multicast Sparse Mode (PIM-SM)

Protocol Independent Multicast (PIM) is a method of forwarding traffic to multicast groups over the network using any pre-existing unicast routing protocol, such as RIP or OSPF, set on routers within a multicast network. Protocol Independent Multicast Sparse Mode (PIM-SM) protocol builds unidirectional shared trees rooted at a Rendezvous Point (RP) per group, and optionally creates shortest-path trees per source. Protocol Independent Multicast Source-Specific Multicast (PIM-SSM) builds trees that are rooted in just one source, offering a more secure and scalable model for a limited number of applications.

PIM-SM Settings

This page is used to set up the PIM-SM table for the ToughNet Secure Router.

PIM-SM Setting

Shortest Path Tree switchover method Never ▾

| Enable | Interface Name | IP Address | Hello Interval(sec) | DR Priority | Join-Prune Interval(sec) |
|--------------------------|----------------|-----------------|---------------------------------|--------------------------------|---------------------------------|
| <input type="checkbox"/> | LAN | 192.168.127.254 | <input type="text" value="30"/> | <input type="text" value="1"/> | <input type="text" value="60"/> |
| <input type="checkbox"/> | V10 | 172.10.1.2 | <input type="text" value="30"/> | <input type="text" value="1"/> | <input type="text" value="60"/> |
| <input type="checkbox"/> | V20 | 172.20.1.2 | <input type="text" value="30"/> | <input type="text" value="1"/> | <input type="text" value="60"/> |
| <input type="checkbox"/> | V100 | 172.100.1.2 | <input type="text" value="30"/> | <input type="text" value="1"/> | <input type="text" value="60"/> |
| <input type="checkbox"/> | V200 | 172.200.1.2 | <input type="text" value="30"/> | <input type="text" value="1"/> | <input type="text" value="60"/> |

Apply

Shortest Path Tree Switchover Method

| Setting | Description | Factory Default |
|-----------------|---|-----------------|
| Never/Immediate | Define how Shortest Path Tree switch over | Never |

Enable (individual)

| Setting | Description | Factory Default |
|----------------|--|-----------------|
| Enable/Disable | Enable or disable PIM-SM by the selected interface | Disable |



NOTE

Only one multicast routing protocol can be enabled at a time. DVMRP and PIM-SM can NOT be enabled simultaneously.

When using PIM-SM as multicast routing alongside unicast routing, either static routes or RIP are recommended.

PIM-SM RP Settings

This page is used to set up the PIM-SM RP settings for the ToughNet Secure Router.

There are two RP Election Methods: Bootstrap and Static.

Bootstrap

PIM-SM RP Setting

PIM-SM RP Election

PIM-SM RP election method

Candidate BSR priority 0 is the lowest

Candidate BSR hash mask length

Candidate RP priority 0 is the highest

Group Setting

Group address

Group address mask

| Multicast Group address | Group address mask |
|-------------------------|--------------------|
| | |

Candidate BSR Priority

| Setting | Description | Factory Default |
|----------|-------------------------------------|-----------------|
| 0 to 255 | Define the priority of BSR election | 64 |

Candidate BSR Hash Mask Length

| Setting | Description | Factory Default |
|---------|---|-----------------|
| 4 to 32 | Define the Hash mask length of BSR election | 30 |

Candidate RP Priority

| Setting | Description | Factory Default |
|----------|------------------------------------|-----------------|
| 0 to 255 | Define the priority of RP election | 192 |

Group Address

| Setting | Description | Factory Default |
|---------------|--------------------------|-----------------|
| Group Address | Define the group address | None |

Group Address Mask

| Setting | Description | Factory Default |
|-------------------------------------|--------------------------------|-----------------|
| 4(240.0.0.0) to 32(255.255.255.255) | Select the group address mask. | None |

Static

PIM-SM RP Setting

PIM-SM RP Election

PIM-SM RP election method

Group address

Group address mask

RP address

| Group Address | Group Address Mask | RP Address |
|---------------|--------------------|------------|
|---------------|--------------------|------------|

Group Address

| Setting | Description | Factory Default |
|---------------|--------------------------|-----------------|
| Group Address | Define the group address | None |

Group Address Mask

| Setting | Description | Factory Default |
|-------------------------------------|--------------------------------|-----------------|
| 4(240.0.0.0) to 32(255.255.255.255) | Select the group address mask. | None |

RP Address

| Setting | Description | Factory Default |
|------------|-----------------------|-----------------|
| RP Address | Define the RP address | None |

PIM-SM SSM Settings

This page is used to set up the PIM-SM SSM settings for the ToughNet Secure Router.

PIM-SM SSM Setting

PIM-SM SSM Range

Enable

Group address

Group address mask

| Multicast Group address | Group address mask |
|-------------------------|--------------------|
|-------------------------|--------------------|

Enable PIM-SSM

| Setting | Description | Factory Default |
|----------------|---------------------------|-----------------|
| Enable/Disable | Enable or disable PIM-SSM | Disable |

Group Address

| Setting | Description | Factory Default |
|---------------|--------------------------|-----------------|
| Group Address | Define the group address | None |

Group Address Mask

| Setting | Description | Factory Default |
|-------------------------------------|--------------------------------|-----------------|
| 4(240.0.0.0) to 32(255.255.255.255) | Select the group address mask. | None |

PIM-SM RP-Set Table

PIM-SM RP Set Table

BSR IP Address 0.0.0.0

BSR Priority 0

BSR Hash Mask Length 0

Page 1/1 ▾

| RP IP Address | Group Prefix | Priority | Hold Time |
|---------------|--------------|----------|-----------|
|---------------|--------------|----------|-----------|

PIM-SM RP-Set Table

This is a table showing the current PIM-SM RP-Set table.

PIM-SM Neighbor Table

PIM-SM Neighbors Table

Page 1/1 ▾

| Index | Neighbor IP | Interface Name | Expire Time |
|-------|-------------|----------------|-------------|
|-------|-------------|----------------|-------------|

PIM-SM Neighbor Table

This is a table showing the current PIM-SM Neighbor table.

Multicast Forwarding Table

The table shows the current Multicast Forwarding Status.

Multicast Forwarding Table

Page 1/1 ▾

| Index | Group Address | Source Address | Inbound Interface | Packets | Bytes | Outbound Interface(s) |
|-------|---------------|----------------|-------------------|---------|-------|-----------------------|
|-------|---------------|----------------|-------------------|---------|-------|-----------------------|

5. Network Redundancy

Layer 2 Redundant Protocols

Configuring RSTP

The following figures indicate which Rapid Spanning Tree Protocol parameters can be configured. A more detailed explanation of each parameter follows.

Communication Redundancy

Current Status
Root/Not root: ---

Settings
Redundancy Protocol: RSTP (IEEE 802.1D 2004)
Bridge Priority: 32768
Forwarding Delay: 15
Hello Time: 2
Max Age: 20

| Port | Enable RSTP | Edge Port | Port Priority | Port Cost | Status |
|------|--------------------------|-----------|---------------|-----------|--------|
| 1 | <input type="checkbox"/> | False | 128 | 200000 | --- |
| 2 | <input type="checkbox"/> | False | 128 | 200000 | --- |
| 3 | <input type="checkbox"/> | False | 128 | 200000 | --- |
| 4 | <input type="checkbox"/> | False | 128 | 200000 | --- |
| 5 | <input type="checkbox"/> | False | 128 | 200000 | --- |
| 6 | <input type="checkbox"/> | False | 128 | 200000 | --- |
| 7 | <input type="checkbox"/> | False | 128 | 200000 | --- |
| 8 | <input type="checkbox"/> | False | 128 | 200000 | --- |
| 9 | <input type="checkbox"/> | False | 128 | 200000 | --- |
| 10 | <input type="checkbox"/> | False | 128 | 200000 | --- |
| 11 | <input type="checkbox"/> | False | 128 | 200000 | --- |
| 12 | <input type="checkbox"/> | False | 128 | 200000 | --- |
| 13 | <input type="checkbox"/> | False | 128 | 200000 | --- |
| 14 | <input type="checkbox"/> | False | 128 | 200000 | --- |
| 15 | <input type="checkbox"/> | False | 128 | 200000 | --- |
| 16 | <input type="checkbox"/> | False | 128 | 200000 | --- |

Apply

At the top of this page, the user can check the **Current Status** of this function. For RSTP, you will see:

Now Active:

It shows which communication protocol is being used—Turbo Ring, RSTP, or neither.

Root/Not Root

This field only appears when RSTP mode is selected. The field indicates whether or not this switch is the Root of the Spanning Tree (the root is determined automatically).

At the bottom of this page, the user can configure the **Settings** of this function. For RSTP, you can configure:

Redundancy Protocol

| Setting | Description | Factory Default |
|---------------------------------------|---|-------------------------|
| Turbo Ring V2/RSTP (IEEE 802.1D 2004) | Select the specific protocol to change to the respective configuration page | RSTP (IEEE 802.1D 2004) |

Bridge priority

| Setting | Description | Factory Default |
|----------------------------------|---|------------------------|
| Numerical value selected by user | Increase this device's bridge priority by selecting a lower number. A device with a higher bridge priority has a greater chance of being established as the root of the Spanning Tree topology. | 32768 |

Forwarding Delay (sec.)

| Setting | Description | Factory Default |
|-------------------------------|---|------------------------|
| Numerical value input by user | The amount of time this device waits before checking to see if it should change to a different state. | 15 |

Hello time (sec.)

| Setting | Description | Factory Default |
|-------------------------------|--|------------------------|
| Numerical value input by user | The root of the Spanning Tree topology periodically sends out a "hello" message to other devices on the network to check if the topology is healthy. The "hello time" is the amount of time the root waits between sending hello messages. | 2 |

Max. Age (sec.)

| Setting | Description | Factory Default |
|-------------------------------|--|------------------------|
| Numerical value input by user | If this device is not the root, and it has not received a hello message from the root in an amount of time equal to "Max. Age," then this device will reconfigure itself as a root. Once two or more devices on the network are recognized as a root, the devices will renegotiate to set up a new Spanning Tree topology. | 20 |

Enable RSTP per Port

| Setting | Description | Factory Default |
|----------------|--|-----------------|
| Enable/Disable | Select to enable the port as a node on the Rapid Spanning Tree Protocol. | Disabled |



NOTE

We suggest not enabling the Rapid Spanning Tree Protocol once the port is connected to a device (PLC, RTU, etc.) as opposed to network equipment. The reason is that it will cause unnecessary negotiation.

| Setting | Description | Factory Default |
|------------|--|-----------------|
| Force Edge | The port is fixed as an edge port and will always be in the forwarding state | False |
| False | The port is set as the normal RSTP port | |

Port Priority

| Setting | Description | Factory Default |
|----------------------------------|---|-----------------|
| Numerical value selected by user | Increase this port's priority as a node on the Spanning Tree topology by entering a lower number. | 128 |

Port Cost

| Setting | Description | Factory Default |
|-------------------------------|---|-----------------|
| Numerical value input by user | Input a higher cost to indicate that this port is less suitable as a node for the Spanning Tree topology. | 200000 |

Port Status

Indicates the current Spanning Tree status of this port. **Forwarding** for normal transmission, or **Blocking** to block transmission.

Configuring Turbo Ring V2

Communication Redundancy

Turbo Ring V2 Status

Now Active

Ring 1

Status

Master/Slave

Master ID

1st Ring Port Status

2nd Ring Port Status

Turbo Ring V2 Setting

Redundancy Protocol Turbo Ring V2

Enable Ring 1

Set as Master

Redundant ports

Turbo Ring V2

Break

Master

02:44:44:44:44:44

Down,Disable

Down,Disable

1st Port 7

2nd Port 8

Apply

Explanation of “Current Status” Items

Now Active

It shows which communication protocol is in use: **Turbo Ring V2** or **RSTP**.

Ring 1—Status

It shows **Healthy** if the ring is operating normally, and shows **Break** if the ring’s backup link is active.

Ring 1—Master/Slave

It indicates whether or not this ToughNet Secure Router is the Master of the Turbo Ring.



NOTE

The user does not need to set the master to use Turbo Ring. If master is not set, the Turbo Ring protocol will assign master status to one of the TN units in the ring. The master is only used to determine which segment serves as the backup path.

Ring Port Status

The “Ports Status” indicators show **Forwarding** for normal transmission, **Blocking** if this port is connected to a backup path and the path is blocked, and **Link down** if there is no connection.

Explanation of “Settings” Items

Redundancy Protocol

| Setting | Description | Factory Default |
|---------------------------------------|---|-------------------------|
| Turbo Ring V2/RSTP (IEEE 802.1D 2004) | Select the specific protocol to change to the respective configuration page | RSTP (IEEE 802.1D 2004) |

Enable Ring

| Setting | Description | Factory Default |
|----------|-----------------------------|-----------------|
| Enabled | Enable the Ring 1 settings | Not checked |
| Disabled | Disable the Ring 1 settings | Not checked |

Set as Master

| Setting | Description | Factory Default |
|----------|-------------------------------------|-----------------|
| Enabled | Select this device as Master | Not checked |
| Disabled | Do not select this device as Master | |

Redundant Ports

| Setting | Description | Factory Default |
|----------|---|-----------------|
| 1st Port | Select any port of the device to be one of the redundant ports. Avoid selecting ports that are part of any bridge interface to preserve topology stability. | 7 |
| 2nd Port | Select any port of the device to be one of the redundant ports. Avoid selecting ports that are part of any bridge interface to preserve topology stability. | 8 |

Layer 3 Redundant Protocols

VRRP Settings

VRRP Setting

VRRP Global Setting

Enable

Version VRRP_v3 ▼

VRRP Interface Setting Entry

Enable

Interface ----- ▼

Virtual IP 0.0.0.0

Virtual Router ID 1 (1-255)

Priority 100 (1-254)

Preemption Mode

Advertisement Interval (cs) 100 (1-4095, 1cs = 10ms)

Accept Mode

VRRP Tracking

Native Interface Tracking ----- ▼

Object Ping Tracking

Target IP 0.0.0.0 (Leave empty or 0.0.0.0 to disable.)

Interval (sec) 1 (1-100)

Timeout (sec) 3 (1-100)

Success Count 3 (1-100)

Failure Count 3 (1-100)

Add
Delete
Modify

VRRP Interface Table (0/16)

| Enable | Index | Interface | IP Address | VRRP Status | Virtual IP | Virtual Router ID | Priority | Advertisement Interval (cs) | Preemption Mode | Accept Mode | Tracking | |
|--------|-------|-----------|------------|-------------|------------|-------------------|----------|-----------------------------|-----------------|-------------|-----------|------|
| | | | | | | | | | | | Interface | Ping |
| | | | | | | | | | | | | |

Apply

Virtual Router Redundancy Protocol (VRRP) can solve the problem with static configuration. VRRP enables a group of routers to form a single virtual router with a virtual IP address. The LAN clients can then be configured with the virtual router's virtual IP address as their default gateway. The virtual router is the combination of a group of routers, and is also known as a VRRP group.

VRRP Global Setting

| Setting | Description | Factory Default |
|---------|----------------------------------|-----------------|
| Enable | Enables VRRP | Disable |
| Version | Choose to use VRRP v2 or VRRP v3 | VRRP v3 |

VRRP Interface Setting Entry

| Setting | Description | Factory Default |
|-----------------------------|--|-----------------|
| Enable | Enables VRRP entry | Disabled |
| Interface | Select a specific interface | None |
| Virtual IP | L3 switches / routers in the same VRRP group must be set to the same virtual IP address as the VRRP ID. This virtual IP address must belong to the same address range as the real IP address of the interface. This virtual IP must not conflict with any existing Layer 3 interface IP addresses. | 0.0.0.0 |
| Virtual Router ID | Virtual Router ID is used to assign a VRRP group. The L3 switches / routers, which operate as master / backup, should have the same ID. Moxa L3 switches / routers support one virtual router ID for each interface. IDs can range from 1 to 255. | 0 |
| Priority | Determines priority in a VRRP group. The priority value range is 1 to 255 and the 255 is the highest priority. If several L3 switches / routers have the same priority, the router with higher IP address has the higher priority. The usable range is "1 to 255". | 100 |
| Preemption Mode | Determines whether a backup L3 switch / router will take the authority of master or not. | Enabled |
| Advertisement Interval (cs) | Specify the VRRP Advertisement Interval time, ranging from 1 to 4095 cs. 1 cs equals 10 ms. | 100 |
| Accept Mode | Enable or disable Accept Mode. | Disabled |

VRRP Tracking

VRRP interface tracking is used to track a specific interface of the router that can change the status of the virtual router for a VRRP Group. For example, the WAN interface can be tracked and if the link is down, the other backup router will become the new master of the VRRP group.

| Setting | Description | Factory Default |
|--------------------------------|---|-----------------|
| Native Interface Tracking | Select the interface to track | None |
| Object Ping Tracking-Target IP | Specify the target IP address to be tracked | 0.0.0.0 |

| Setting | Description | Factory Default |
|-------------------------------------|--|-----------------|
| Object Ping Tracking-Interval (sec) | Specify the tracking interval in seconds | 1 |
| Object Ping Tracking-Timeout (sec) | Specify the timeout period in seconds | 3 |
| Object Ping Tracking-Success Count | Specify the success count | 3 |
| Object Ping Tracking-Fail Count | Specify the failure count | 3 |

6. Network Address Translation

Network Address Translation (NAT)

NAT Concept

NAT (Network Address Translation) is a common security function for changing the IP address during Ethernet packet transmission. When the user wants to hide the internal IP address (LAN) from the external network (WAN), the NAT function will translate the internal IP address to a specific IP address, or an internal IP address range to one external IP address. The benefits of using NAT include:

- Uses the N-1 or Port forwarding NAT function to hide the Internal IP address of a critical network or device to increase the level of security of industrial network applications.
- Uses the same private IP address for different, but identical, groups of Ethernet devices. For example, 1-to-1 NAT makes it easy to duplicate or extend identical production lines.



NOTE

The NAT function will check if incoming or outgoing packets match the policy. It starts by checking the packet with the first policy (Index=1); if the packet matches this policy, the ToughNet Secure Router will translate the address immediately and then start checking the next packet. If the packet does not match this policy, it will check with the next policy.



NOTE

The maximum number of NAT policies for the ToughNet Secure Router is 512.

1-to-1 NAT

If the internal device and external device need to communicate with each other, choose 1-to-1 NAT, which offers bi-directional communication (N-to-1 and Port forwarding are both single-directional communication NAT functions).

1-to-1 NAT is usually used when you have a group of internal servers with private IP addresses that must connect to the external network. You can use 1-to-1 NAT to map the internal servers to public IP addresses. The IP address of the internal device will not change.

The figure below illustrates how a user could extend production lines, and use the same private IP addresses of internal devices in each production line. The internal private IP addresses of these devices will map to different public IP addresses. Configuring a group of devices for 1-to-1 NAT is easy and straightforward.

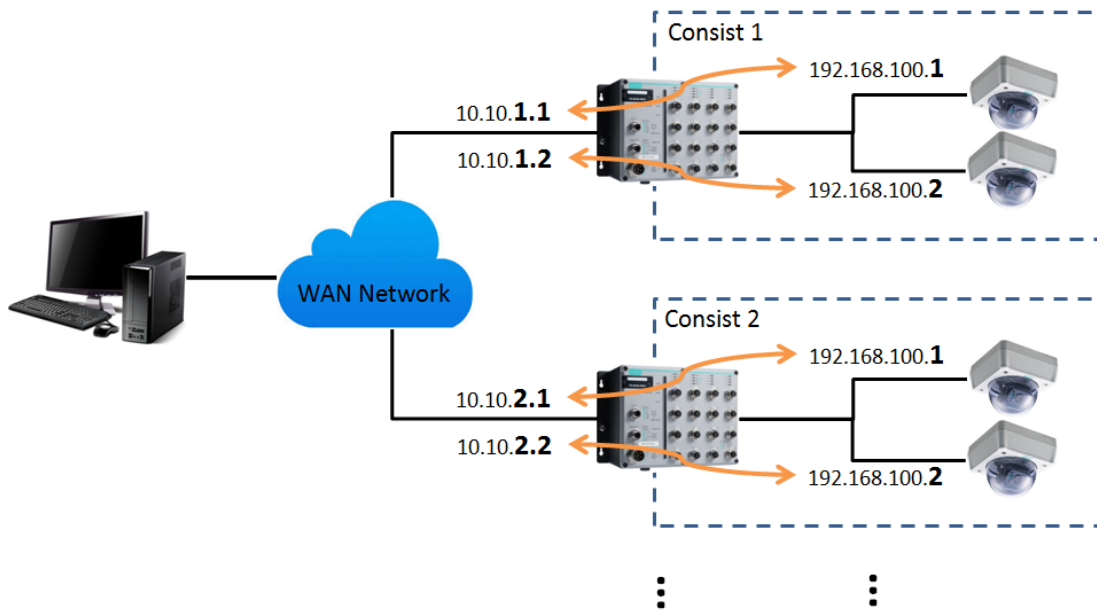

1-to-1 NAT Setting in TN-5916 for Consist 1

| NAT List (2/512) | | | | | | | |
|------------------|-------|----------|-----------|---------------|-------------|----------------|------------------|
| Enable | Index | Protocol | Interface | Source IP | Source Port | Destination IP | Destination Port |
| ✓ | 1 | -- | WAN | 192.168.100.1 | -- | 10.10.1.1 | -- |
| ✓ | 2 | -- | WAN | 192.168.100.2 | -- | 10.10.1.2 | -- |

1-to-1 NAT Setting in TN-5916 for Consist 2

| NAT List (2/512) | | | | | | | |
|------------------|-------|----------|-----------|---------------|-------------|----------------|------------------|
| Enable | Index | Protocol | Interface | Source IP | Source Port | Destination IP | Destination Port |
| ✓ | 1 | -- | WAN | 192.168.100.1 | -- | 10.10.2.1 | -- |
| ✓ | 2 | -- | WAN | 192.168.100.2 | -- | 10.10.2.2 | -- |

| | | | |
|--------------|--------------------------|-------------------|---------|
| Enable | <input type="checkbox"/> | Outside Interface | ----- v |
| NAT Mode | 1-1 v | Global IP | |
| VRRP Binding | -- v | Local IP | |

Enable/Disable NAT policy

| Setting | Description | Factory Default |
|-------------------|---|-----------------|
| Enable or Disable | Enable or disable the selected NAT policy | Disable |

NAT Mode

| Setting | Description | Factory Default |
|-----------------|---------------------|-----------------|
| 1-to-1 | Select the NAT type | 1-to-1 |
| N-to-1 | | |
| Port Forwarding | | |

VRRP Binding

| Setting | Description | Factory Default |
|------------|--|-----------------|
| VRRP Index | Select the VRRP rule if there are Master and Slave routers using the same NAT 1-1 setting. | None |

Outside Interface

| Setting | Description | Factory Default |
|-----------|--------------------------------|-----------------|
| Interface | The interface of the Global IP | None |

Global IP

| Setting | Description | Factory Default |
|------------|---|-----------------|
| IP Address | The Global IP address in the LAN network area | None |

Local IP

| Setting | Description | Factory Default |
|------------|--|-----------------|
| IP Address | The Local IP address in the LAN network area | None |



NOTE

The ToughNet Secure Router can obtain an IP address via DHCP or PPPoE. However, if this dynamic IP address is the same as the WAN IP for 1-to-1 NAT, then the 1-to-1 NAT function will not work. For this reason, we recommend disabling the DHCP/PPPoE function when using the 1-to-1 NAT function.

N-to-1 NAT

If the user wants to hide the Internal IP address from users outside the LAN, the easiest way is to use the N-to-1 (or N-1) NAT function. The N-1 NAT function replaces the source IP Address with an external IP address, and adds a logical port number to identify the connection of this internal/external IP address. This function is also called "Network Address Port Translation" (NAPT) or "IP Masquerading."

The N-1 NAT function is a one-way connection from an internal secure area to an external non-secure area. The user can initialize the connection from the internal to the external network, but may not be able to initialize the connection from the external to the internal network.

| | | | |
|--------------|--------------------------|-------------------|---------|
| Enable | <input type="checkbox"/> | Outside Interface | ----- v |
| NAT Mode | N-1 v | Global IP | 0.0.0.0 |
| VRRP Binding | - v | Local IP | ~ |

Enable/Disable NAT Policy

| Setting | Description | Factory Default |
|-------------------|---|-----------------|
| Enable or Disable | Enable or disable the selected NAT policy | Disable |

NAT Mode

| Setting | Description | Factory Default |
|-----------------|---------------------|-----------------|
| 1-to-1 | Select the NAT type | 1-to-1 |
| N-to-1 | | |
| Port Forwarding | | |

Outside Interface

| Setting | Description | Factory Default |
|-----------|--------------------------------|-----------------|
| Interface | The interface of the Global IP | None |

Global IP

| Setting | Description | Factory Default |
|------------|---|-----------------|
| IP Address | The IP address of the user-selected interface in this N-to-1 policy | None |

Local IP

| Setting | Description | Factory Default |
|------------|--|-----------------|
| IP Address | Specify the Local IP range for IP translation to the Global IP address | None |

Add a NAT Rule

Checked the "Enable" checkbox and input the correspondent NAT parameters in the page, and then click "New/Insert" to add it into the NAT List Table. Finally, click "Apply" to activate the configuration.

Delete a NAT Rule

Select the item in the NAT List Table, then, click "Delete" to delete the item.

Modify a NAT Rule

Select the item in the NAT List Table. Modify the attributes and click "Modify" to change the configuration.

Activate NAT List Table

After adding/deleting/modifying any NAT Rules, be sure to click Apply.

Port Forward

If the initial connection is from outside the LAN, but the user still wants to hide the Internal IP address, one way to do this is to use the Port Forwarding NAT function.

The user can specify the port number of an external IP address in the Port Forwarding policy list. For example, if the IP address of an IP camera on the internal network is 192.168.127.10 with port 80, the user can set up a port forwarding policy to let remote users connect to the internal IP camera from external IP address 10.10.10.10 through port 8080. The ToughNet Secure Router will transfer the packet to IP address 192.168.127.10 through port 80.

The Port Forwarding NAT function is one way of connecting from an external insecure area (WAN) to an internal secure area (LAN). The user can initiate the connection from the external network to the internal network, but will not able to initiate a connection from the internal network to the external network.

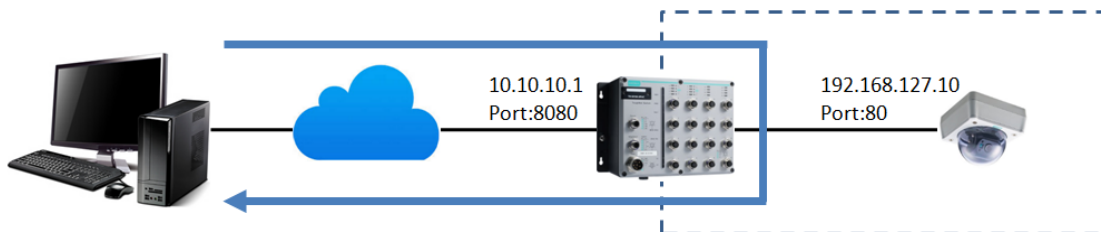

| | | | |
|--------------|--------------------------|-------------------|----------------------|
| Enable | <input type="checkbox"/> | Outside Interface | ----- v |
| NAT Mode | Port Forwarding v | Global Port | <input type="text"/> |
| VRRP Binding | -- v | Local Port | <input type="text"/> |
| | | Local IP | <input type="text"/> |
| | | Protocol | TCP v |

Enable/Disable NAT policy

| Setting | Description | Factory Default |
|-------------------|---|-----------------|
| Enable or Disable | Enable or disable the selected NAT policy | Disable |

NAT Mode

| Setting | Description | Factory Default |
|-------------------------------------|---------------------|-----------------|
| 1-to-1 N-to-1 Port Forwarding | Select the NAT type | 1-to-1 |

Outside Interface

| Setting | Description | Factory Default |
|-----------|--------------------------------|-----------------|
| Interface | The interface of the Global IP | None |

Global Port

| Setting | Description | Factory Default |
|------------|------------------------------|-----------------|
| 1 to 65535 | Specify a Global port number | None |

Local Port

| Setting | Description | Factory Default |
|------------|---|-----------------|
| 1 to 65535 | The translated port number in the Local network | None |

Local IP

| Setting | Description | Factory Default |
|------------|--|-----------------|
| IP address | The translated IP address in the Local network | WAN IP address |

Protocol

| Setting | Description | Factory Default |
|-------------------------|--|-----------------|
| TCP UDP TCP & UDP | Select the protocol for the NAT policy | TCP |

7. Firewall

Policy Concept

The ToughNet Secure Router supports Firewall functionality. A firewall device is commonly used to provide secure traffic control over an Ethernet network, as illustrated in the figure below. Firewall devices are deployed at critical points between an external network (the non-secure part) and an internal network (the secure part).

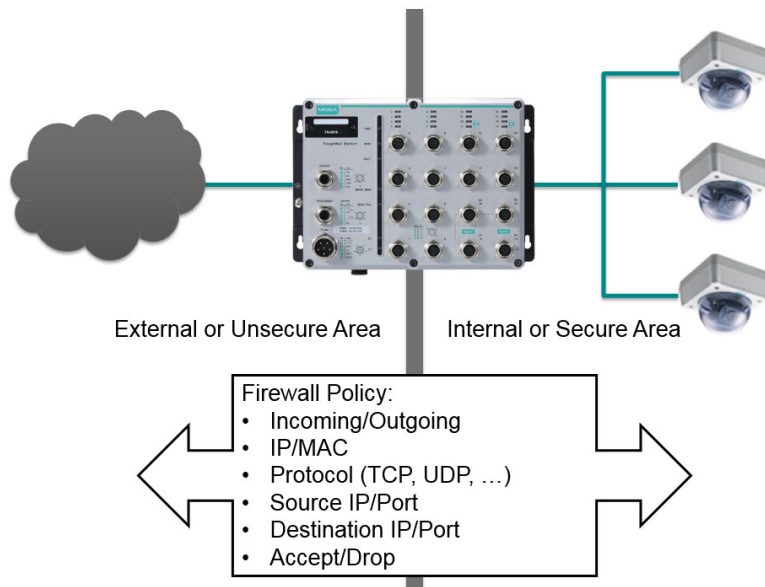

Policy Overview

The ToughNet Secure Router has a Firewall Policy Overview that lists firewall policies by interface direction.

Policy Overview

Interface From To

Filter List (1/512)

| Enable | Index | Input | Output | Protocol | Source IP | Source Port | Destination IP | Destination Port | Source MAC Address | Action |
|-------------------------------------|-------|-------|--------|----------|-----------|-------------|----------------|------------------|--------------------|--------|
| <input checked="" type="checkbox"/> | 1 | ALL | ALL | All | All | All | All | All | -- | ACCEPT |

Select the **From** interface and **To** interface and then click the **Show** button. The Policy list table will show the policies that match the **From-To** interface.

Interface From/To

| Setting | Description | Factory Default |
|-----------|--|-----------------|
| Interface | Select the From Interface and To Interface | From ALL To ALL |

Policy Setup

The ToughNet Secure Router's Firewall policy provided secure traffic control, allowing users to control network traffic based on the following parameters.

Policy Setup

Global Setting
 Firewall Event Log:

Policy Setting
 Enable:
 Severity: Flash Syslog SNMP Trap
 Action:
 Source IP:
 Source Port:
 Destination IP:
 Destination Port:
 Interface: From To
 Quick Automation Profile:
 Service:

| Enable | Index | Input | Output | Protocol | Source IP | Source MAC Address | Source Port | Destination IP | Destination Port | Action | Event Log / Severity |
|-------------------------------------|-------|-------|--------|----------|-----------|--------------------|-------------|----------------|------------------|--------|-------------------------|
| <input checked="" type="checkbox"/> | 1 | ALL | ALL | All | All | -- | All | All | All | ACCEPT | Disable / <0> Emergency |

Global Setting

Firewall Event Log

| Setting | Description | Factory Default |
|----------------|--|-----------------|
| Enable/Disable | Enable or disable the Firewall event log | Enable |

Policy Setting

Policy Enable/Disable

| Setting | Description | Factory Default |
|----------------|--|-----------------|
| Enable/Disable | Enable or disable the selected Firewall Policy | Enable |

Severity

| Setting | Description | Factory Default |
|--|---|-----------------|
| <0> emergency <1> Alert <2> Critical <3> Error <4> Warning <5> Notice <6> Information <7> Debug | Select the severity level of the selected policy | <0> emergency |
| Flash Syslog SNMP Trap | Select the warning method for the selected policy | None |

Interface From/To

| Setting | Description | Factory Default |
|-----------|--|-----------------|
| Interface | Select the From Interface and To Interface | From ALL To ALL |

Quick Automation Profile

| Setting | Description | Factory Default |
|---|---|-----------------|
| Refer to the "Quick Automation Profile" section | Select the Protocol parameters in the Firewall policy | All |

Service

| Setting | Description | Factory Default |
|------------|--|-----------------|
| IP Filter | This Firewall policy will filter by IP address | IP Filter |
| MAC Filter | This Firewall policy will filter by source MAC address | |

Action

| Setting | Description | Factory Default |
|---------|---|-----------------|
| ACCEPT | The packet will be accepted by the firewall when it matches this firewall policy | ACCEPT |
| DROP | The packet will not be accepted by the firewall when it does not match this firewall policy | |

Source IP

| Setting | Description | Factory Default |
|---------|---|-----------------|
| All | The Firewall policy will check all Source IP addresses in the packet | All |
| Single | The Firewall policy will check single Source IP address in the packet | |
| Range | The Firewall policy will check multiple Source IP addresses in the packet | |

Source MAC

| Setting | Description | Factory Default |
|-------------|--|-----------------|
| MAC Address | The Firewall policy will check the Source MAC address in the packet. | None |

Source Port

| Setting | Description | Factory Default |
|---------|---|-----------------|
| All | The Firewall policy will check all the Source port numbers in the packet | All |
| Single | The Firewall policy will check the single Source port numbers in the packet | |
| Range | The Firewall policy will check multiple Source port numbers in the packet | |

Destination IP

| Setting | Description | Factory Default |
|----------------|--|------------------------|
| All | The Firewall policy will check all Destination IP addresses in the packet | All |
| Single | The Firewall policy will check single Destination IP address in the packet | |
| Range | The Firewall policy will check multiple Destination IP addresses in the packet | |

Destination Port

| Setting | Description | Factory Default |
|----------------|--|------------------------|
| All | The Firewall policy will check all Destination port numbers in the packet | All |
| Single | The Firewall policy will check single Destination port numbers in the packet | |
| Range | The Firewall policy will check multiple Destination port numbers in the packet | |



NOTE

The ToughNet Secure Router's firewall function will check if incoming or outgoing packets match the firewall policy. It starts by checking the packet with the first policy (Index=1); if the packet matches this policy, it will accept the packet immediately and then check the next packet. If the packet does not match this policy it will check with the next policy.



NOTE

The maximum number of Firewall policies for the ToughNet Secure Router TN-5916 is 512.

Quick Automation Profile

Ethernet Fieldbus protocols are popular in industrial automation applications. In fact, many Fieldbus protocols (e.g., EtherNet/IP and Modbus TCP/IP) can operate on an industrial Ethernet network, with the Ethernet port number defined by IANA (Internet Assigned Numbers Authority). The ToughNet Secure Router provides an easy to use function called Quick Automation Profile that includes many different pre-defined

profiles (Modbus TCP/IP, Ethernet/IP, etc.), allowing users to create an industrial Ethernet Fieldbus firewall policy with a single click.

For example, if the user wants to create a Modbus TCP/IP firewall policy for an internal network, the user just needs to select the **Modbus TCP/IP (TCP)** or **Modbus TCP/IP (UDP)** protocol from the **Quick Automation Profile** drop-down menu on the Firewall Policy Setting page.

The screenshot shows the 'Policy Setup' configuration page. It includes several settings:

- Enable:** Checked.
- Action:** ACCEPT (dropdown).
- Interface:** From ALL (dropdown) To ALL (dropdown).
- Quick Automation Profile:** All (dropdown, highlighted with a red box).
- Service:** IP Filter (dropdown).
- Source IP:** All (dropdown).
- Source Port:** All (dropdown).
- Destination IP:** All (dropdown).
- Destination Port:** All (dropdown).

The following table shows the Quick Automation Profile for Ethernet Fieldbus Protocol and the corresponding port number.

| Ethernet Fieldbus Protocol | Port Number |
|---|-------------|
| EtherNet/IP I/O (TCP) | 2222 |
| EtherNet/IP I/O (UDP) | 2222 |
| EtherNet/IP Messaging (TCP) | 44818 |
| EtherNet/IP Messaging (UDP) | 44818 |
| FF Annunciation (TCP) | 1089 |
| FF Annunciation (UDP) | 1089 |
| FF Fieldbus Message Specification (TCP) | 1090 |
| FF Fieldbus Message Specification (UDP) | 1090 |
| FF System Management (TCP) | 1091 |
| FF System Management (UDP) | 1091 |
| FF LAN Redundancy Port (TCP) | 3622 |

| Ethernet Fieldbus Protocol | Port Number |
|---|-------------|
| FF LAN Redundancy Port (UDP) | 3622 |
| LonWorks (TCP) | 2540 |
| LonWorks (UDP) | 2540 |
| LonWorks2 (TCP) | 2541 |
| LonWorks2 (UDP) | 2541 |
| Modbus TCP/IP (TCP) | 502 |
| Modbus TCP/IP (UDP) | 502 |
| PROFINet RT Unicast (TCP) | 34962 |
| PROFINet RT Unicast (UDP) | 34962 |
| PROFINet RT Multicast (TCP) | 34963 |
| PROFINet RT Multicast (UDP) | 34963 |
| PROFINet Context Manager (TCP) | 34964 |
| PROFINet Context Manager (UDP) | 34964 |
| IEC 60870-5-104 process control over IP (TCP) | 2404 |
| IEC 60870-5-104 process control over IP (UDP) | 2404 |
| DNP (TCP) | 20000 |
| DNP (UDP) | 20000 |
| Ethercat (TCP) | 34980 |
| Ethercat (UDP) | 34980 |

The Quick Automation Profile also includes the commonly used Ethernet protocols listed in the following table.

| Ethernet Protocol | Port Number |
|---------------------------|-------------|
| IPsec NAT-Traversal (TCP) | 4500 |
| IPsec NAT-Traversal (UDP) | 4500 |
| FTP-data (TCP) | 20 |
| FTP-data (UDP) | 20 |
| FTP-control (TCP) | 21 |
| FTP-control (UDP) | 21 |
| SSH (TCP) | 22 |
| SSH (UDP) | 22 |
| Telnet (TCP) | 23 |
| Telnet (UDP) | 23 |
| HTTP (TCP) | 80 |
| HTTP (UDP) | 80 |
| IPsec (TCP) | 1293 |
| IPsec (UDP) | 1293 |
| L2TP (TCP) | 1701 |
| L2TP (UDP) | 1701 |
| PPTP (TCP) | 1723 |

| Ethernet Protocol | Port Number |
|-------------------------|-------------|
| PPTP (UDP) | 1723 |
| RADIUS (TCP) | 1812 |
| RADIUS (UDP) | 1812 |
| RADIUS Accounting (TCP) | 1813 |
| RADIUS Accounting (UDP) | 1813 |
| TRDP PD (UDP) | 17224 |
| TRDP MD (TCP) | 17225 |
| TRDP MD (UDP) | 17225 |

Layer 2 Policy Setup

The ToughNet Secure Router provides an advanced Layer 2 firewall policy for secure traffic control, which depends on the following parameters. Layer 2 firewall policy can filter packets from bridge ports. Layer 2 policy priority is higher than the Layer 3 policy.

Layer 2 Policy Setup

Enable
 Action

Interface From To
 Source MAC Address

EtherType
 Destination MAC Address

Filter List (0/256)

| Enable | Index | Input | Output | Protocol | Source MAC Address | Destination MAC Address | Action |
|--------|-------|-------|--------|----------|--------------------|-------------------------|--------|
|--------|-------|-------|--------|----------|--------------------|-------------------------|--------|

Policy Enable/Disable

| Setting | Description | Factory Default |
|----------------|--|-----------------|
| Enable/Disable | Enable or disable the selected Firewall Policy | Disable |

Interface From/To

| Setting | Description | Factory Default |
|---------|----------------------------------|-----------------|
| Port | Select the From Port and To Port | From ALL To ALL |

EtherType

| Setting | Description | Factory Default |
|------------------|---|-----------------|
| 0x0600 to 0xFFFF | Select the EtherType parameter in the Firewall policy. When the Protocol is set to "Manual" you can set up EtherType manually | All |

Action

| Setting | Description | Factory Default |
|---------|---|-----------------|
| ACCEPT | The packet will be accepted by the firewall when it matches this firewall policy | ACCEPT |
| DROP | The packet will not be accepted by the firewall when it does not match this firewall policy | |

Source MAC Address

| Setting | Description | Factory Default |
|-------------|---|-----------------|
| MAC Address | The Firewall policy will check the Source MAC address in the packet | None |

Destination MAC Address

| Setting | Description | Factory Default |
|----------------|--|------------------------|
| MAC Address | The Firewall policy will check Destination MAC address in the packet | None |

The following table shows the Layer 2 protocol types commonly used in Ethernet frames.

| Layer 2 Protocol | Type |
|------------------------------------|-------------|
| IPv4 (Internet Protocol version 4) | 0x0800 |
| X.25 | 0x0805 |
| ARP (Address Resolution Protocol) | 0x0806 |
| Frame Relay ARP | 0x0808 |
| G8BPQ AX.25 Ethernet Packet | 0x08FF |
| DEC Assigned proto | 0x6000 |
| DEC DNA Dump/Load | 0x6001 |
| DEC DNA Remote Console | 0x6002 |
| DEC DNA Routing | 0x6003 |
| DEC LAT | 0x6004 |
| DEC Diagnostics | 0x6005 |
| DEC Customer use | 0x6006 |
| DEC Systems Comms Arch | 0x6007 |
| Trans Ether Bridging | 0x6558 |
| Raw Frame Relay | 0x6559 |

| Layer 2 Protocol | Type |
|--|--------|
| Appletalk AARP | 0x80F3 |
| Appletalk | 0x809B |
| Novell IPX | 0x8100 |
| NetBEUI | 0x8137 |
| IP version 6 (Internet Protocol version 6) | 0x8191 |
| PPP | 0x86DD |
| MultiProtocol over ATM | 0x880B |
| PPPoE discovery messages | 0x884C |
| PPPoE session messages | 0x8863 |
| Frame-based ATM Transport over Ethernet | 0x8864 |
| Loopback | 0x8884 |

Denial of Service (DoS) Defense

The ToughNet Secure Router provides many different DoS functions for detecting or defining abnormal packet format or traffic flow. The ToughNet Secure Router will drop the packets when it detects an abnormal packet format. The ToughNet Secure Router will also monitor some traffic flow parameters and activate the defense process when abnormal traffic conditions are detected.

DoS (Deny of Service) Setting

DoS(Deny of Service) Setting

Session SYN Protection

TCP Sessions Without SYN

Port-Scan Protection

Null Scan
 Xmas Scan
 NMAP-Xmas Scan
 SYN/FIN Scan
 FIN Scan
 NMAP-ID Scan
 SYN/RST Scan

Flood Protection

ICMP-Flood Limit: (pkt/s)
 SYN-Flood Limit: (pkt/s)
 ARP-Flood Limit: (pkt/s)

DoS Log Setting

Log Enable Severity Flash Syslog SNMP Trap

Apply

Session SYN Protection

TCP Sessions Without SYN

| Setting | Description | Factory Default |
|----------------|--|-----------------|
| Enable/Disable | Enable or disable the NEW-Without-SYN Scan | Disable |

Port Scan Protection

Null Scan

| Setting | Description | Factory Default |
|----------------|---------------------------------|-----------------|
| Enable/Disable | Enable or disable the Null Scan | Disable |

Xmas Scan

| Setting | Description | Factory Default |
|----------------|---------------------------------|-----------------|
| Enable/Disable | Enable or disable the Xmas Scan | Disable |

NMAP-Xmas Scan

| Setting | Description | Factory Default |
|----------------|--------------------------------------|-----------------|
| Enable/Disable | Enable or disable the NMAP-Xmas Scan | Disable |

SYN/FIN Scan

| Setting | Description | Factory Default |
|----------------|------------------------------------|-----------------|
| Enable/Disable | Enable or disable the SYN/FIN Scan | Disable |

FIN Scan

| Setting | Description | Factory Default |
|----------------|--------------------------------|-----------------|
| Enable/Disable | Enable or disable the FIN Scan | Disable |

NMAP-ID Scan

| Setting | Description | Factory Default |
|----------------|------------------------------------|-----------------|
| Enable/Disable | Enable or disable the NMAP-ID Scan | Disable |

SYN/RST Scan

| Setting | Description | Factory Default |
|----------------|------------------------------------|------------------------|
| Enable/Disable | Enable or disable the SYN/RST Scan | Disable |

Flood Protection

ICMP-Flood

| Setting | Description | Factory Default |
|--------------------------------------|--|------------------------|
| Enable/Disable | Enable or disable the ICMP-Death defense | Disable |
| Limit: 50 to 4000 (Packet/Second) | The limit value to activate ICMP-Death defense | 0 |

SYN-Flood

| Setting | Description | Factory Default |
|--------------------------------------|---|------------------------|
| Enable/Disable | Enable or disable the SYN-Flood defense | Disable |
| Limit: 50 to 4000 (Packet/Second) | The limit value to activate SYN-Flood defense | 0 |

ARP-Flood

| Setting | Description | Factory Default |
|--------------------------------------|---|------------------------|
| Enable/Disable | Enable or disable the ARP-Flood defense | Disable |
| Limit: 50 to 4000 (Packet/Second) | The limit value to activate ARP-Flood defense | 0 |

DoS Log Setting

Log Enable

| Setting | Description | Factory Default |
|----------------|-------------------------------|------------------------|
| Enable/Disable | Enable or disable the DoS log | Disable |

Severity

| Setting | Description | Factory Default |
|--|---|-----------------|
| <0> emergency <1> Alert <2> Critical <3> Error <4> Warning <5> Notice <6> Information <7> Debug | Select the severity level of the DoS log | <0> emergency |
| Flash Syslog SNMP Trap | Select the warning method for the DoS log | None |

TRDP Packet Filter

The TRDP (Train Real-time Data Protocol) is the communication protocol used among various on-board systems to ensure secure and reliable communication. The TN-5916 switch implements TRDP ComID filtering using L3 allowlist filtering, which operates when TRDP communication occurs between different IP subnets.

With this feature, only TRDP packets that are explicitly listed in the allowlist are permitted to pass through, regardless of whether they are PD (Process Data), MD (Message Data), unicast, or multicast. Any TRDP packets not included in the whitelist will be dropped. However, if TRDP communication is confined to the same LAN (Local Area Network), the TN-5916 switch will not enforce any filtering rules.

TRDP Filter Setting

Global Setting

Enable Allow List

Enable Drop Malformed Packets

TRDP Service PD Port

TRDP Service MD Port

Policy Setting

Enable

From To

ComID

TRDP Filter List (0/128)

| Enable | Index | Input | Output | ComID |
|--------|-------|-------|--------|-------|
|--------|-------|-------|--------|-------|

Global Setting

| Setting | Description | Factory Default |
|-------------------------------|--|-----------------|
| Enable Allow List | Enable Allow list to filter TRDP packets | Disabled |
| Enable Drop malformed Packets | Enable Drop Malformed Packets to filter malformed TRDP packets | Disabled |
| TRDP Service PD Port | Specify the TRDP Service PD Port | 17224 |
| TRDP Service MD Port | Specify the TRDP Service MD Port | 17225 |

Policy Setting

Once **Allow List** is enabled, configure TRDP Filter List. only the TRDP packets in whitelist are allowed to pass.

| Setting | Description | Factory Default |
|----------------|--|-----------------|
| Enable/Disable | Enable to activate TRDP filter policy | Disable |
| From | Specify the inbound interface | ALL |
| To | Specify the outbound interface | ALL |
| ComID | Specify the ComID which is allowed to pass | 0 |



Note

Once the TRDP **Allow List** is enabled, TRDP packets is only filtered by TRDP filtering, not by the L3 firewall. L3 firewall policies won't be applied to TRDP packets and therefore have no effect on said packets.

When **Drop Malformed Packets** is enabled, any malformed TRDP packets are dropped. After this initial filtering, TRDP ComID filtering is applied to the remaining TRDP packets.

Firewall Degraded Mode

Moxa routers can act as firewalls to help provide protection from external attacks that try to gain access and control over the network. On the other hand, while protecting the network, it is also important to prevent potential malfunctions that may occur and avoid unexpected network operation failures.

To handle this, Firewall Degraded Mode is a monitoring and protection mechanism that monitors important indicators and enters Firewall Degraded Mode once user-defined failure criteria are reached to ensure that device operation remains stable.

Firewall Degraded Mode Criteria

The criteria for entering and leaving Firewall Degraded Mode are defined by the following:

- **Performance Thresholds:** If the CPU utilization % exceeds a user-defined threshold, or the amount of free memory % goes below a user-defined threshold, a failure will be detected for the current cycle.
- **Monitoring Interval:** This defines how long a single monitoring cycle will be.
- **Number of Cycles to Enter Firewall Degraded Mode:** This defines how many consecutive cycles with failures are required to enter Firewall Degraded Mode.
- **Number of Cycles to Leave Firewall Degraded Mode:** This defines how many consecutive cycles without failures are required to leave Firewall Degraded Mode.
- **Critical Services:** If any of the following critical services are enabled, the device continually check to see whether the services are alive. The device will enter Firewall Degraded Mode if any enabled critical service is no longer alive, and all enabled critical services must be alive to leave Firewall Degraded Mode.

The critical services that apply to Firewall Degraded Mode are as follows:

- DHCP Server
- DHCP Relay Agent
- SNMP Server
- Turbo Ring V2



Warning

When the device is operating normally, its CPU and memory usage can vary due to various factors. Apart from potential attacks, the number of devices connected to the router and application settings can also lead to increased demands on CPU and memory.

It is important to carefully assess the usage and configuration of this feature to avoid triggering Firewall Degraded Mode due to normal usage to avoid impacting regular operations.

Entering Firewall Degraded Mode

The device will enter Firewall Degraded Mode when any of the following occur:

- The number of consecutive cycles with failures reaches the defined Number of Cycles to Enter Firewall Degraded Mode
- Any of the enabled Critical Services are no longer alive

When in Firewall Degraded Mode

In Firewall Degraded Mode, the device will do the following:

- Block all traffic (both ingress and egress) on the interfaces where firewall rules are applied
- Log the event and the reason for the event in the system log



Warning

When Firewall Degraded Mode is enabled, the port settings and VLAN settings should not be modified in order to prevent a mismatch for the Firewall Degraded Mode interface settings.

Leaving Firewall Degraded Mode

The device will leave Firewall Degraded Mode under any of the following conditions:

- The number of normal consecutive cycles without failures reaches the defined **Normal Cycles to Leave Firewall Degraded Mode** AND all enabled **Critical Services** are alive.
- The device is restarted. After restarting, the device will enter normal operation and will only enter Firewall Degraded Mode if the criteria are fulfilled.

When leaving Firewall Degraded Mode, the device will do the following:

- Resume all traffic (both ingress and egress) on the interfaces where firewall rules are applied
- Log the event in the system log

Firewall Degraded Mode

Firewall degraded mode

| | |
|---------------------------------------|--|
| Status | <input type="text" value="Not in firewall degraded mode"/> |
| Enable | <input type="checkbox"/> |
| Interface | <input type="text" value="-----"/> |
| CPU utilization threshold (%) | <input type="text" value="70"/> (1~90) |
| Free memory space threshold (%) | <input type="text" value="20"/> (1~50) |
| Status monitoring interval (sec) | <input type="text" value="1"/> (1~5) |
| Failure cycles to enter degraded mode | <input type="text" value="5"/> (3~10) |
| Normal cycles to leave degraded mode | <input type="text" value="5"/> (3~10) |

| Setting | Description | Factory Default |
|---|--|-----------------|
| Status | Enable or Disable this VPN Tunnel | None |
| Enabled/Disable | Enable or disable Firewall degraded mode | Disabled |
| Interface | Specify which interface Firewall degraded mode will apply to. When in Firewall degraded mode, all traffic on this interface (both ingress and egress) will be blocked. | None |
| CPU utilization threshold (%) | Specify the maximum CPU utilization % allowed. If the CPU utilization % goes over this threshold, a failure will be triggered for the current cycle. | 70 |
| Free memory storage space threshold (%) | Specify the minimum free memory % allowed. If the free memory % goes below this threshold, a failure will be triggered for the current cycle. | 20 |

| Setting | Description | Factory Default |
|---------------------------------------|--|-----------------|
| Status monitoring interval (sec) | Specify a cycle time in seconds to monitor CPU and memory usage for failure detection. | 1 |
| Failure cycles to enter degraded mode | Specify the number of consecutive cycles with failures allowed before entering Firewall degraded mode. | 5 |
| Normal cycles to leave degraded mode | Specify the required number of normal consecutive cycles without failures to leave Firewall degraded mode. | 5 |

Virtual Private Network (VPN)

Overview

In this section we describe how to use the ToughNet Secure Router to build a secure Remote Automation network with the VPN (Virtual Private Network) feature. A VPN provides a highly cost effective solution of establishing secure tunnels, so that data can be exchanged in a secure manner.

There are three several applications for secure remote communication:

IPsec (Internet Protocol Security) VPN for LAN to LAN Security: Data communication only in a pre-defined IP range between two different LANs.

L2TP (Layer 2 Tunnel Protocol) VPN for Remote roaming User: It is for a remote roaming user with a dynamic IP to create a VPN. L2TP is a popular choice for remote roaming users for VPN applications because the L2TP VPN protocol is already built in to the Microsoft Windows operating system.

IPsec uses IKE (Internet Key Exchange) protocol for Authentication, Key exchange and provides a way for the VPN gateway data to be protected by different encryption methods.

There are 2 phases for IKE for negotiating the IPsec connections between 2 VPN gateways:

Key Exchange (IPsec Phase 1): The 2 VPN gateways will negotiate how IKE should be protected. Phase 1 will also authenticate the two VPN gateways by the matched Pre-Shared Key or X.509 Certificate.

Data Exchange (IPsec Phase 2): In Phase 2, the VPN gateways negotiate to determine additional IPsec connection details, which include the data encryption algorithm.

IPsec Configuration

IPsec configuration includes 5 parts:

- **Global Setting:** Enable or Disable all IPsec Tunnels and NAT-Traversal functions
- **Tunnel Setting:** Set up the VPN Connection type and the VPN network plan
- **Key Exchange:** Authentication for 2 VPN gateways
- **Data Exchange:** Data encryption between VPN gateways
- **Dead Peer Detection:** The mechanism for VPN Tunnel maintenance

Global Settings

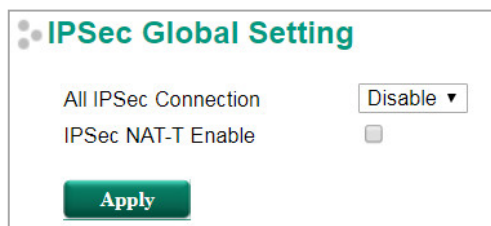

The screenshot shows a configuration window titled "IPSec Global Setting". It contains two settings: "All IPsec Connection" with a dropdown menu set to "Disable", and "IPsec NAT-T Enable" with an unchecked checkbox. An "Apply" button is located at the bottom left of the window.

The ToughNet Secure Router provides 3 Global Settings for IPsec VPN applications.

All IPsec Connection

Users can Enable or Disable all IPsec VPN services with this configuration.



NOTE

The factory default setting is Disable, so when the user wants to use IPsec VPN function, make sure the setting is enabled.

IPsec NAT-T Enable

If there is an external NAT device between VPN tunnels, the user must enable the NAT-T (NAT-Traversal) function.

IPsec Settings

IPsec Quick Setting

The ToughNet Secure Router's **Quick Setting** mode can be used to easily set up a site-to-site VPN tunnel for two Industrial Secure Router units.

Setting **Quick Setting** **Advanced Setting**

When choosing the Quick setting mode, the user just needs to configure the following:

- Tunnel Setting
- Security Setting
- Encryption Strength: Simple (AES-128), Standard (AES-192), Strong (AES-256)
- Password of Pre-Shared Key



NOTE

The Encryption strength and Pre-Shared key should be configured identically for both ToughNet Secure Router units.

IPsec Advanced Setting

Click **Advanced Setting** to configure detailed VPN settings.

Setting **Quick Setting** **Advanced Setting**

Tunnel Setting

| Tunnel Setting | | | |
|---------------------|--------------------------|--------------------|--------------------------|
| Enable | <input type="checkbox"/> | Name | <input type="text"/> |
| | | L2TP tunnel | <input type="checkbox"/> |
| VPN Connection Type | Site to Site | Remote VPN Gateway | 0.0.0.0 |
| Startup Mode | Start in initial | | |
| Local Network | 192.168.127.254 | Netmask | 255.255.255.0 |
| Remote Network | 0.0.0.0 | Netmask | <input type="text"/> |
| Identity Type | IP Address | Local ID | <input type="text"/> |
| | | Remote ID | <input type="text"/> |

Enable or Disable VPN Tunnel

| Setting | Description | Factory Default |
|-------------------|-----------------------------------|-----------------|
| Enable or Disable | Enable or Disable this VPN Tunnel | Disable |

Name of VPN Tunnel

| Setting | Description | Factory Default |
|-----------------------|---------------------------------------|-----------------|
| Max. of 16 characters | User defined name of this VPN Tunnel. | None |

**NOTE**

The first character cannot be a number.

L2TP over IPsec Enable or Disable

| Setting | Description | Factory Default |
|-------------------|-----------------------------------|-----------------|
| Enable or Disable | Enable or Disable L2TP over IPsec | None |

VPN Connection Type

| Setting | Description | Factory Default |
|--------------------|--|-----------------|
| Site to Site | VPN tunnel for Local and Remote subnets are fixed | Site to Site |
| Site to Site (Any) | VPN tunnel for Remote subnet area is dynamic and Local subnet is fixed | |

Remote VPN Gateway

| Setting | Description | Factory Default |
|------------|---------------------------------|-----------------|
| IP Address | Remote VPN Gateway's IP Address | 0.0.0.0 |

Startup Mode

| Setting | Description | Factory Default |
|---------------------|--|------------------|
| Start in Initial | This VPN tunnel will actively initiate the connection with the Remote VPN Gateway. | Start in Initial |
| Wait for Connecting | This VPN tunnel will wait remote VPN gateway to initiate the connection | |



NOTE

The maximum number of **Starts** in the initial VPN tunnel is 30. The maximum number of **Waits** for connecting to a VPN tunnel is 100.

Local Network

| Setting | Description | Factory Default |
|---------|--|-----------------|
| Network | The IP address of the local VPN network. | 192.168.127.254 |

Netmask

| Setting | Description | Factory Default |
|---------|---|-----------------|
| Netmask | The subnet mask of the local VPN network. | 255.255.255.0 |

Remote Network

| Setting | Description | Factory Default |
|---------|-----------------------------------|-----------------|
| Network | IP address of remote VPN network. | 0.0.0.0 |

Netmask

| Setting | Description | Factory Default |
|---------|--|-----------------|
| Netmask | The subnet mask of the remote VPN network. | None |

Identity

| Setting | Description | Factory Default |
|-----------|--|-----------------|
| Type | <p>There are four ID types for users to choose from: IP address, FQDN, Key ID, and Auto.</p> <p>Key ID is a string, which users can create by themselves.</p> <p>Auto (with Cisco) is for building connections for use with Cisco's systems.</p> | IP address |
| Local ID | ID for identifying the VPN tunnel connection. The Local ID must be equal to the Remote ID of the connected VPN Gateway. Otherwise, the VPN tunnel cannot be established successfully. | |
| Remote ID | ID for identifying the VPN tunnel connection. The Local ID must be equal to the Remote ID of the connected VPN Gateway. Otherwise, the VPN tunnel cannot be established successfully. | |

Key Exchange (IPsec phase 1)

Key Exchange (Phase 1)

IKE Mode:

Authentication Mode:

Encryption Algorithm: Hash Algorithm:

DH Group:

Negotiation Times: (0:forever) IKE Life Time: hour.

Rekey Expire Time: min. Rekey Fuzz Percent: %

IKE Mode

| Setting | Description | Factory Default |
|------------|--|-----------------|
| Main | In 'Main' IKE Mode, both the Remote and Local VPN gateway will negotiate which Encryption/Hash algorithm and DH groups can be used in this VPN tunnel; both VPN gateways must use the same algorithm to communicate. | MAIN |
| Aggressive | In "Aggressive" Mode, the Remote and Local VPN gateway will not negotiate the algorithm; it will use the user's configuration only. | |

Authentication Mode

| Setting | Description | Factory Default |
|----------------|---|-----------------|
| Pre-Shared Key | When two systems use a Pre-Shared Key which users define as an authentication tool to build an IPsec VPN connection. | Pre-Shared Key |
| X.509 | In this mode, two systems use certificates that users imported in advance in "Local Certificate" as an authentication tool to build an IPsec VPN connection. For the detailed workflow, please refer to User Scenario 1 and 2 later in this chapter. | N/A |
| X.509 With CA | In this mode, two systems use certificates that users imported in advance in "Local Certificate", and the CA that users imported in advance in "Trusted CA Certificate" as an authentication tool to build an IPsec VPN connection. For the detailed workflow, please refer to User Scenario 3, 4, and 5 later in this chapter. | N/A |

For the detailed workflow of X.509 and X.509 with CA, please refer to the user scenarios 1 to 5 below later in this chapter.



NOTE

Certificates are a time related form of authentication. Before processing certificates, please ensure that the industrial secure router is synced with the local device. For more information about time sync, please refer to the Date and Time section.

Encryption Algorithm

| Setting | Description | Factory Default |
|---------|--------------------------------------|-----------------|
| DES | | |
| 3DES | | |
| AES-128 | Encryption Algorithm in key exchange | 3DES |
| AES-192 | | |
| AES-256 | | |
| | | |

Hash Algorithm

| Setting | Description | Factory Default |
|-------------------------------|--------------------------------|------------------------|
| Any MD5 SHA1 SHA-256 | Hash Algorithm in key exchange | SHA1 |

DH Group

| Setting | Description | Factory Default |
|--|--|------------------------|
| DH1(modp 768) DH2(modp 1024) DH5(modp 1536) DH14(modp 2048) | Diffie-Hellman groups (the Key Exchange group between the Remote and VPN Gateways) | DH2(modp 1024) |

Negotiation Time

| Setting | Description | Factory Default |
|------------------|---|------------------------|
| Negotiation time | The number of allowed reconnect times when startup mode is initiated. If the number is 0, this tunnel will always try connecting to the remote gateway when the VPN tunnel is not created successfully. | 0 |

IKE Lifetime

| Setting | Description | Factory Default |
|----------------------|---------------------|------------------------|
| IKE lifetime (hours) | Lifetime for IKE SA | 1 (hr) |

Rekey Expire Time

| Setting | Description | Factory Default |
|-----------------------------|--|------------------------|
| Rekey expire time (minutes) | Start to Rekey before the IKE lifetime has expired | 9 (min) |

Rekey Fuzz Percent

| Setting | Description | Factory Default |
|-----------|---|-----------------|
| 0-100 (%) | The key exchange interval will change randomly to enhance security. "Rekey Expire Time" is the baseline interval to exchange keys. Rekey fuzz percent represents the percentage of how much "Rekey Expire Time" will change. For example, the "Rekey Expire Time" is set as 9 mins, and "Rekey Fuzz Percent" is set as 50%. The key exchange interval will be 4.5 mins. | 100% |

Data Exchange (IPsec phase 2)

| Data Exchange (Phase 2) | | | |
|-------------------------|---------------------------------------|--------------------------|--|
| SA Life Time | <input type="text" value="480"/> min. | Perfect Forward Security | <input type="checkbox"/> <input type="text" value="DH 1 (modp768)"/> |
| Encryption Algorithm | <input type="text" value="3DES"/> | Hash Algorithm | <input type="text" value="SHA1"/> |

SA Lifetime

| Setting | Description | Factory Default |
|-----------------------|----------------------------|-----------------|
| SA lifetime (minutes) | Lifetime for SA in Phase 2 | 480 (min) |

Perfect Forward Security

| Setting | Description | Factory Default |
|--|--|-----------------|
| Enable or Disable | Uses different security keys for different IPsec phases in order to enhance security | Disable |
| DH1 (modp768) DH2 (modp1024) DH5 (modp1536) DH14 (modp2048) | Diffie-Hellman groups (the Key Exchange group between the Remote and VPN Gateways) | DH1 (modp768) |

Encryption Algorithm

| Setting | Description | Factory Default |
|--------------|---------------------------------------|-----------------|
| DES | Encryption Algorithm in data exchange | 3DES |
| 3DES | | |
| AES-128 | | |
| AES-192 | | |
| AES-256 NULL | | |

Hash Algorithm

| Setting | Description | Factory Default |
|---------|---------------------------------|-----------------|
| Any | Hash Algorithm in data exchange | SHA1 |
| MD5 | | |
| SHA1 | | |
| SHA-256 | | |

Dead Peer Detection

Dead Peer Detection is a mechanism to detect whether or not the connection between a local secure router and a remote IPsec tunnel has been lost.

Dead Peer Detection
Action Retry Interval seconds Confidence Interval seconds

Action

Action when a dead peer is detected.

| Setting | Description | Factory Default |
|---------|-----------------------------|-----------------|
| Hold | Hold this VPN tunnel | Restart |
| Restart | Reconnect this VPN tunnel | |
| Disable | Disable Dead Peer Detection | |

Delay

| Setting | Description | Factory Default |
|----------------------|--|------------------------|
| Delay time (seconds) | The period of dead peer detection messages | 30 (sec) |

Timeout

| Setting | Description | Factory Default |
|-------------------|--|------------------------|
| Timeout (seconds) | Timeout to check if the connection is alive or not | 120 (sec) |

IPsec Use Case Demonstration

In the following section, we will consider five common user scenarios. The purpose of each example is to give a clearer understanding of two authentication modes 'X.509' and 'X.509 with CA'.



NOTE

Certificates are a time related form of authentication. Before processing certificates, please ensure that the ToughNet Secure Router is synced with the local device. For more information about time sync, please refer to the Date and Time section.

Scenario 1: X.509 Mode-One Certificate

Users will sometimes use certificates generated from a server or from the Internet. If users only get one certificate, they can import this certificate into a system. This system can then use the same certificate to identify other certificates and then build a VPN connection. In this case, users have to import certificates (.p12) into both sides. Please follow the steps in the diagram below to learn how to install certificates and build an IPsec VPN connection.

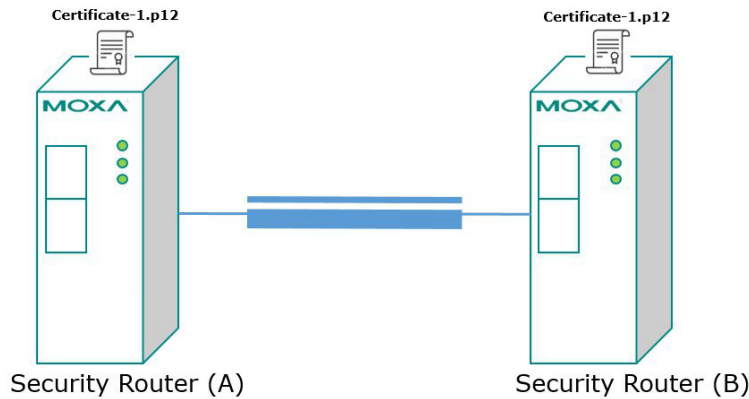

1. Import **Certificate-1.p12** file in "Local Certificate", and label it a number. Here take No.1 as an example.
2. Enter "IPSec setting", and in "Advanced Setting", select X.509 authentication mode.
3. In "Local", select No.1
4. In "Remote", select No.1

1. Import **Certificate-1.p12** file in "Local Certificate", and label it a number. Here take No.1 as an example.
2. Enter "IPSec setting", and in "Advanced Setting", select X.509 authentication mode.
3. In "Local", select No.1
4. In "Remote", select No.1

Scenario 2: X.509 Mode-Two Certificates

Users will sometimes use certificates generated from a server or from the Internet. If users get different certificates for different systems, users can import these certificates into systems accordingly. However, systems require all of these certificates to identify trusted systems before building an IPsec VPN connection. Taking two systems as an example: System A has certificate-1 (.p12) and System B has certificate-2 (.p12). To build an IPsec VPN connection, System A and B have to exchange certificates (.crt) with each other. And then Systems A and B need to install certificates (.crt) into their systems. Please follow the steps in the diagram below to learn how to install certificates and build an IPsec VPN connection.

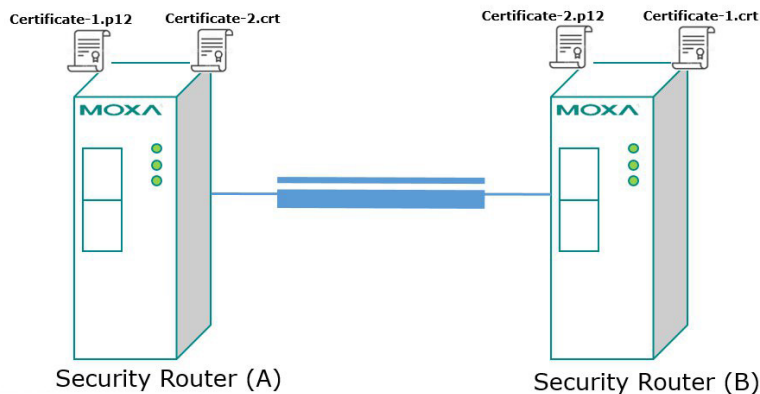

1. Import **Certificate-1.p12** file in "Local Certificate", and label it a number. Here take No.1 as an example.
2. Import **Certificate-2.crt** file or **Certificate-2.p12** file in "Local Certificate", and label it a number. Here take No.2 as an example.
3. Enter "IPSec setting", and in "Advanced Setting", select X.509 authentication mode.
4. In "Local", select No.1
5. In "Remote", select No.2

1. Import **Certificate-2.p12** file in "Local Certificate", and label it a number. Here take No.1 as an example.
2. Import **Certificate-1.crt** file or **Certificate-1.p12** file in "Local Certificate", and label it a number. Here take No.2 as an example.
3. Enter "IPSec setting", and in "Advanced Setting", select X.509 authentication mode.
4. In "Local", select No.2
5. In "Remote", select No.1

Scenario 3: X.509 with CA Mode-One CA

In X.509 mode, users have to install all certificates in all systems, which takes a lot of time and effort. To decrease users' effort, they can get the certificate from the CA (Certificate Authority). When using certificates from the CA, each system needs to install the same CA (.crt) to allow each system to identify different certificates from different systems. One condition is that every certificate should be issued by the same CA. Please follow the steps in the diagram below to learn how to install CA (.crt) and build an IPsec connection.

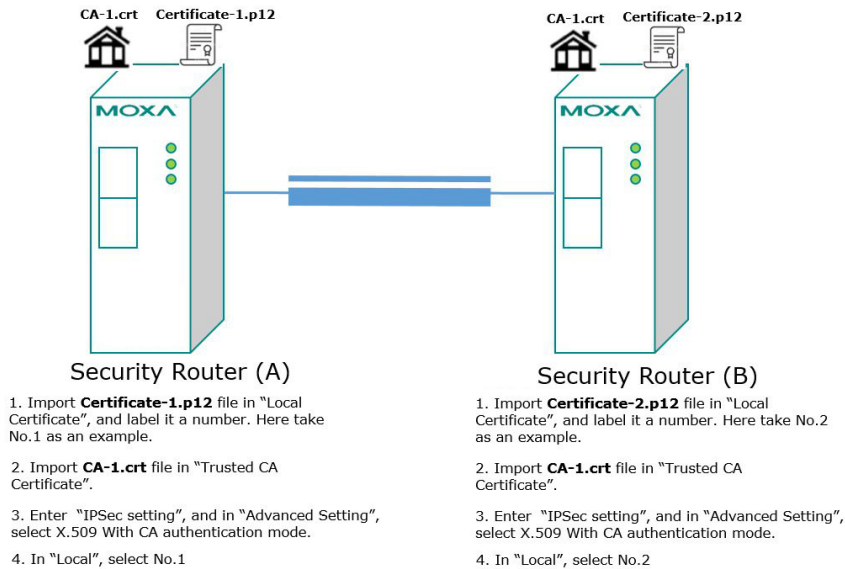

Scenario 4: X.509 with CA Mode-Two CAs

In some large-scale systems, users may find it difficult to get certificates from one CA and therefore need to get certificates from different CAs. This scenario applies to the X.509 CA mode. The users have to install all CAs (.crt) into all systems. This means that every system can recognize certificates from different CAs, which allows identification of all the different systems. Please follow the steps in the diagram below to learn how to install CA (.crt) and certificate (.p12) in order to build an IPsec connection.

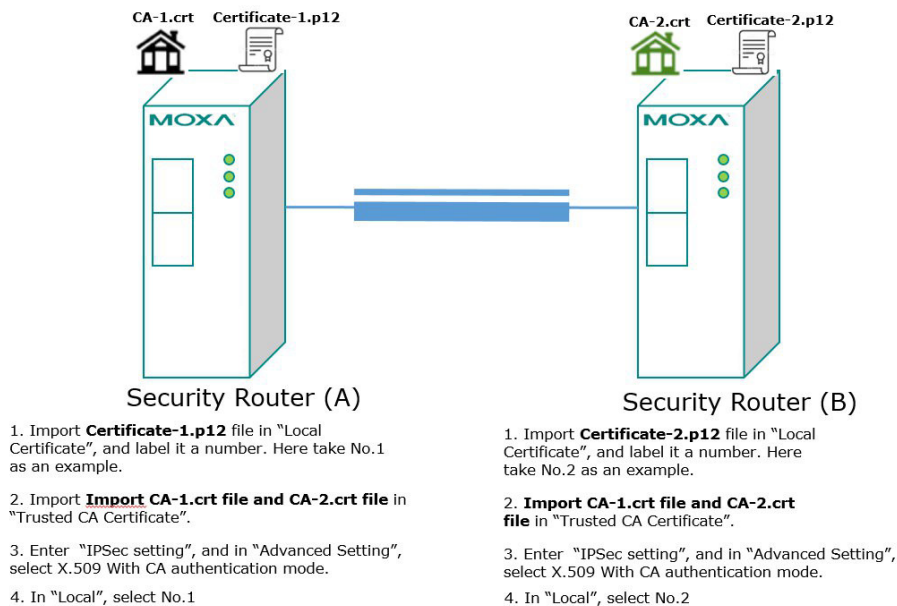

Scenario 5: X.509 with CA Mode-Certificate from CSR

For the previous four user scenarios, even when systems use certificates to identify each other before building a VPN connection, there is still a risk that someone can steal the certificate and pretend to be part of the trusted system.

To minimize this risk, there is a function called Certificate Signing Request (CSR) in X.509 with CA mode. CSR is a request issued by a single system for certificates issued by the CA. Through CSR, the certificate belongs only to one system and cannot be installed in other systems. By following this method, CSR significantly reduces the risk of certificates being used illegitimately.

We will now consider an example using System A and System B. The CSR working model is System A or B issues a CSR (.csr) to the CA and then the CA updates the system with the certificate (.crt) and the CA file (.crt). Then, system A or B updates the other system with the CA file (.crt). System A or B installs certificates and the CA file in the system in order to build a VPN connection. Please follow the steps in the diagram below to learn how to install a CA file (.crt) and certificate (.crt) in order to build IPsec connections.

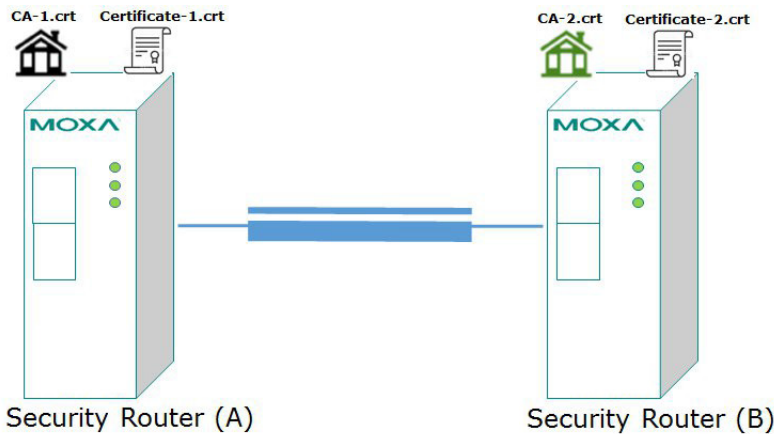

1. Generate Key in "Key Pair Generate", and give it a name. Here take One as an example.
2. Generate CSR in "CSR Generate". Select One in "Private Key". Name this CSR in "Common Name". Here name this CSR as Certificate-1 as an example.
3. Export **Certificate-1.csr** file and send it to CA-1.
4. Download **Certificate-1.crt** and **CA-1.crt** from CA-1.
5. Import **Certificate-1.crt** file in "Local Certificate. In "Import Identity Certificate" select "Certificate From CSR". In "CSR Common Name" select **Certificate-1.csr**.
6. Import **CA-2.crt** file in "Trusted CA Certificate.
7. Enter "IPSec setting", and in "Advanced Setting", select X.509 With CA authentication mode.
8. In "Local", select No.1

1. Generate Key in "Key Pair Generate", and give it a name. Here take Two as an example.
2. Generate CSR in "CSR Generate". Select Two in "Private Key". Name this CSR in "Common Name". Here name this CSR as Certificate-2 as an example.
3. Export **Certificate-2.csr** file and send it to CA-2.
4. Download **Certificate-2.crt** and **CA-2.crt** from CA-1.
5. Import **Certificate-2.crt** file in "Local Certificate. In "Import Identity Certificate" select "Certificate From CSR". In "CSR Common Name" select **Certificate-2.csr**.
6. Import **CA-1.crt** file in "Trusted CA Certificate.
7. Enter "IPSec setting", and in "Advanced Setting", select X.509 With CA authentication mode.
8. In "Local", select No.2

IPsec Status

The user can check the VPN tunnel status in the **IPsec Connection List**.

This list shows the Name of the IPsec tunnel, IP address of Local and Remote Subnet/Gateway, and the established status of the Key exchange phase and Data exchange phase.

IPSec Status

| Name | Local Subnet | Local Gateway | Remote Gateway | Remote Subnet | Key Exchange (Phase 1) | Data Exchange (Phase 2) | Time |
|------|--------------|---------------|----------------|---------------|------------------------|-------------------------|------|
|------|--------------|---------------|----------------|---------------|------------------------|-------------------------|------|

[Prev Page](#) [Next Page](#) [Refresh](#)

L2TP Server (Layer 2 Tunnel Protocol)

L2TP is a popular choice for remote roaming users for VPN applications since an L2TP client is built in to the Microsoft Windows operating system. Since L2TP does not provide an encryption function, it is usually combined with IPsec to provide data encryption.

L2TP Configuration

L2TP Server

Server Setting (WAN)

L2TP Server Mode

Local IP

Offered IP Range ~

[Apply](#)

User Name Settings

User Name Password

[Add](#) [Modify](#)

L2TP Account (0/1)

| User Name |
|-----------|
|-----------|

The Industrial Secure Router supports up to 10 accounts with different user names and passwords.

L2TP Server Mode

| Setting | Description | Factory Default |
|------------------|--|------------------------|
| Enable / Disable | Enable or Disable the L2TP function on the WAN1 or WAN 2 interface | Disable |

Local IP

| Setting | Description | Factory Default |
|----------------|------------------------------------|------------------------|
| IP Address | The IP address of the Local Subnet | 0.0.0.0 |

Offered IP Range

| Setting | Description | Factory Default |
|----------------|--|------------------------|
| IP Address | Offered IP range is for the L2TP clients | 0.0.0.0 |

Login User Name

| Setting | Description | Factory Default |
|---------------------|-------------------------------|------------------------|
| Max. 32 characters. | User Name for L2TP connection | None |

Login Password

| Setting | Description | Factory Default |
|---------------------|------------------------------|------------------------|
| Max. 32 characters. | Password for L2TP connection | None |

8. Certificate Management

For the purposes of this document, certificate management refers to the X.509 SSL certificate. X.509 is a digital certificate method commonly used for IPsec and HTTPS authentication. The ToughNet Secure Router can act as a Root CA (Certificate Authority) and issue a trusted Root Certificate. Alternatively, users can import certificates from other CAs into the ToughNet Secure Router.

Certificates are a time related authentication mechanism. Before processing certificate management, please make ensure the ToughNet secure router is synced with the local device. For more details regarding time sync, please refer to section Date and Time.

Local Certificate

For Local Certificates, users can import certificates issued by the CA into the ToughNet Secure Router.

Local Certificate

Import Identity Certificate

| Setting | Description | Factory Default |
|---|--|-----------------|
| Certificate/ Certificate from CSR/ Certificate from PKCS#12 | <p>Select the type of certificate the user has.</p> <p>Certificate uses the file extension .crt</p> <p>The certificate from CSR is a certificate issued by other CA</p> <p>Certificate from PKCS#12 uses the file extension .p12</p> | Certificate |

Label

| Setting | Description | Factory Default |
|---------|---------------------|-----------------|
| Label | No. of certificates | N/A |



NOTE

When importing the Certificate from PKCS#12, the user has to browse the certificate before typing Import Password.

Trusted CA Certificates

In Trusted CA Certificates, users can import a CA that the user trusts into the ToughNet Secure Router. It is recommended that the user imports a trusted CA in advance. Otherwise, the ToughNet Secure Router may not recognize the certificate and reject the connection.

Trusted CA Certificate

Name

CA Certificate Upload Browse...

Certificate List (0/10)

| Name | Subject |
|------|---------|
|------|---------|

Certificate Signing Request

If the user wants to get a certificate from the CA for connection purposes, then the two steps below need to be followed in order to generate a private key and certificate signing request.

Step1: Generate Private Key

Before sending the Certificate Signing Request (CSR) to the CA, the CSR must include a public key that can be generated with a private key simultaneously. The user can use a private key to encrypt data and the receiver can use a public key to decrypt the data.

Key Pair Generate

Name

Key Pair Size

Key List (0/10)

| Name | Key Pair Size |
|------|---------------|
|------|---------------|

Key Pair Generate

Name

| Setting | Description | Factory Default |
|---------|-------------------------|-----------------|
| Name | Naming each private key | N/A |



NOTE

The user has to click Add before entering the name of each key.

Step2: Generate CSR

After generating the private key, the user can choose the key in Private Key and then must fill in all the information under **Certificate Subject Name**. After that, the user can click **Generate** to create the CSR and the CSR will be displayed in the **Certificate List**. To export the CSR, the user can simply choose the CSR in **Certificate List** and click **Export**.

Certificate Signing Request

Private Key

Certificate Subject Name

Country Name (2 letter code) Locality Name

Organization Name Organizational Unit Name

Common Name Email Address

Subject Alternative Name

Certificate Signing Request

Certificate List

| All | Label | Subject |
|-----|-------|---------|
|-----|-------|---------|

Certificate Signing Request

Private Key

| Setting | Description | Factory Default |
|-------------|---|-----------------|
| Private Key | Choose the key generated in Key Pair Generate | N/A |

CA Server

Aside from getting the certificate from other CAs, the ToughNet Secure Router can act as a RootCA to issue a certificate for each connection. After the RootCA has been set up, the ToughNet Secure Router can send requests to ask for a certificate from the RootCA.

Certificate Request

If a system only has their own certificate on hand, and do not have other systems' certificates, how can the system recognize other systems? The answer to this problem is Trust CA. As mentioned in the section Trust CA certificate, users can import a CA (.cer) that they trust into the ToughNet Secure Router. When the user does this, the system will accept the certificate that was issued by a trusted CA.

If users want to use a certificate issued by the ToughNet Secure Router functioning as a RootCA, the receiver must import this RootCA settings (.cer) as a trusted CA and recognize then it will recognize the RootCA certificate during connection. Otherwise, this connection will be rejected by the receiver. Users can create RootCA via Certificate Request and export the RootCA settings by clicking RootCA Export.

The user has to fill in all the RootCA information in the Certificate Request in order to create the RootCA.

Certificate Setting

After creating the RootCA successfully, users can issue a request for a certificate from the RootCA in the Certificate Setting. After filling in the information, users can generate two kinds of certificate: PKCS#12 (.p12) and certificate (.crt). A PKCS#12 request includes a private key but a certificate does not. To export a PKCS#12 certificate, please click PKCS#12 Export. To export a certificate request, please click Certification Export.

Certificate Create

Certificate Request

Country Name (2 letter code) Certificate days

State or Province Name Locality Name

Organization Name Organizational Unit Name

Common Name Email Address

Certificate Setting

Certificate days Organizational Unit Name

Certificate Name Email Address

Certificate Password

Certificate List (0/10)

| Certificate days | Organizational Unit Name | Name | Email Address | Certificate Password |
|------------------|--------------------------|------|---------------|----------------------|
|------------------|--------------------------|------|---------------|----------------------|

9. Security

User Interface Management

User Interface Management

Enable

| | | | |
|-------------------------------------|--------------|--------------|--|
| <input checked="" type="checkbox"/> | MOXA Utility | Utility Port | <input type="text" value="4000,4001"/> |
| <input checked="" type="checkbox"/> | Telnet | Telnet Port | <input type="text" value="23"/> |
| <input checked="" type="checkbox"/> | SSH | SSH Port | <input type="text" value="22"/> |
| <input checked="" type="checkbox"/> | HTTP | HTTP Port | <input type="text" value="80"/> |
| <input checked="" type="checkbox"/> | HTTPS | SSL Port | <input type="text" value="443"/> |

Maximum Login Users For HTTP+HTTPS (1~10)

Maximum Login Users For Telnet+SSH (1~5)

Auto Logout Setting (min) (0~1440; 0 for Disable)

Enable MOXA Utility

| Setting | Description | Factory Default |
|-----------------|--|-----------------|
| Select/Deselect | Select the appropriate checkboxes to enable MOXA Utility | Selected |

Enable Telnet

| Setting | Description | Factory Default |
|-----------------|--|----------------------|
| Select/Deselect | Select the appropriate checkboxes to enable Telnet | Selected Port: 23 |

Enable SSH

| Setting | Description | Factory Default |
|-----------------|---|----------------------|
| Select/Deselect | Select the appropriate checkboxes to enable SSH | Selected Port: 22 |

Enable HTTP

| Setting | Description | Factory Default |
|-----------------|--|----------------------|
| Select/Deselect | Select the appropriate checkboxes to enable HTTP | Selected Port: 80 |

Enable HTTPS

| Setting | Description | Factory Default |
|-----------------|---|-----------------------|
| Select/Deselect | Select the appropriate checkboxes to enable HTTPS | Selected Port: 443 |

Maximum Login Users For HTTP+HTTPS

| Setting | Description | Factory Default |
|------------------------------------|--|-----------------|
| Maximum Login Users For HTTP+HTTPS | Set a limit for the amount of users who can be logged in using HTTP and HTTPS. The maximum number of users using HTTP and HTTPS is 10. | 5 |

Maximum Login Users For Telnet+SSH

| Setting | Description | Factory Default |
|------------------------------------|---|-----------------|
| Maximum Login Users For Telnet+SSH | Set a limit for the amount of users who can be logged in using HTTP and HTTPS. The maximum supported user numbers of Telnet+SSH is 5. | 5 |

Auto Logout Setting (min)

| Setting | Description | Factory Default |
|---------------------------|--|-----------------|
| Auto Logout Setting (min) | When the user does not touch the ToughNet Secure Router management interface for a defined period of time, the management interface will logout automatically. | 5 |

Authentication Certificate

Authentication certificate refers to certificates that use HTTPS. The web console certificate can be generated by the ToughNet Secure Router automatically or users can choose the certificate imported in Local certificate.

Authentication Certificate

SSL Certificate

| | |
|----------------------|--------------------------|
| Certificate Database | Auto Generate |
| Certificate File | -- |
| Created Date | Aug 1 06:38:45 2017 GMT |
| Expired Date | Jul 27 06:38:45 2036 GMT |
| Re-Generate | <input type="checkbox"/> |

SSH Key

| | |
|--------------|--------------------------|
| Created Date | Aug 1 06:40:55 2017 GMT |
| Re-Generate | <input type="checkbox"/> |

Apply

Certificate Database

| Setting | Description | Factory Default |
|----------------------------|--|-----------------|
| Auto Generate | The ToughNet Secure Router will generate a certificate automatically. If not, please select "Re-Generate" to generate a certificate. Auto Generate is the default setting. | Auto Generate |
| Local Certificate Database | Select the certificate you import into Local Certificate. The certificate that is loaded here is limited to "Certificate from CSR" and "Certificate From PKCS#12". | |

SSH Key Re-generate

| Setting | Description | Factory Default |
|-----------------|--------------------------------|-----------------|
| Select/Deselect | Enable the SSH Key Re-generate | Deselect |

Trusted Access

The ToughNet Secure Router uses an IP address-based filtering method to control access.

Trusted Access

Enable the accessible IP list ("Disable" will allow all IP's connection)

| Enable | Index | IP Address | Netmask |
|--------------------------|-------|----------------------|----------------------|
| <input type="checkbox"/> | 1 | <input type="text"/> | <input type="text"/> |
| <input type="checkbox"/> | 2 | <input type="text"/> | <input type="text"/> |
| <input type="checkbox"/> | 3 | <input type="text"/> | <input type="text"/> |
| <input type="checkbox"/> | 4 | <input type="text"/> | <input type="text"/> |
| <input type="checkbox"/> | 5 | <input type="text"/> | <input type="text"/> |
| <input type="checkbox"/> | 6 | <input type="text"/> | <input type="text"/> |
| <input type="checkbox"/> | 7 | <input type="text"/> | <input type="text"/> |
| <input type="checkbox"/> | 8 | <input type="text"/> | <input type="text"/> |
| <input type="checkbox"/> | 9 | <input type="text"/> | <input type="text"/> |
| <input type="checkbox"/> | 10 | <input type="text"/> | <input type="text"/> |

Trusted Access Log

Log Enable Severity Flash Syslog SNMP Trap

Trusted IP List

You may add or remove IP addresses to limit access to the Moxa ToughNet Secure Router. When the accessible IP list is enabled, only addresses on the list will be allowed access to the Moxa ToughNet Secure Router. Each IP address and netmask entry can be tailored for different situations:

- **Grant access to one host with a specific IP address**
For example, enter IP address 192.168.1.1 with netmask 255.255.255.255 to allow access to 192.168.1.1 only.
- **Grant access to any host on a specific subnetwork**
For example, enter IP address 192.168.1.0 with netmask 255.255.255.0 to allow access to all IPs on the subnet defined by this IP address/subnet mask combination.
- **Grant access to all hosts**
Make sure the accessible IP list is not enabled. Remove the checkmark from Enable the accessible IP list.

The following table shows additional configuration examples:

| Hosts That Need Access | Input Format |
|------------------------------|---------------------------------|
| Any host | Disable |
| 192.168.1.120 | 192.168.1.120 / 255.255.255.255 |
| 192.168.1.1 to 192.168.1.254 | 192.168.1.0 / 255.255.255.0 |

| Hosts That Need Access | Input Format |
|--------------------------------|---------------------------------|
| 192.168.0.1 to 192.168.255.254 | 192.168.0.0 / 255.255.0.0 |
| 192.168.1.1 to 192.168.1.126 | 192.168.1.0 / 255.255.255.128 |
| 192.168.1.129 to 192.168.1.254 | 192.168.1.128 / 255.255.255.128 |

Trusted Access Log

Log Enable

| Setting | Description | Factory Default |
|----------------|--|-----------------|
| Enable/Disable | Enable or disable the Trusted Access log | Disable |

Severity

| Setting | Description | Factory Default |
|--|--|-----------------|
| <0> emergency <1> Alert <2> Critical <3> Error <4> Warning <5> Notice <6> Information <7> Debug | Select the severity level of the Trusted Access log | <0> emergency |
| Flash Syslog SNMP Trap | Select the warning method for the Trusted Access log | None |

Radius Server

The ToughNet Secure Router can be configured to operate as a RADIUS server. RADIUS is a networking protocol that provides centralized Authentication, Authorization, and Accounting (AAA) management for users who connect and use a network service.

Global Settings

RADIUS Server Global Setting

RADIUS Server Enable

Authentication Port

Apply

Severity

| Setting | Description | Factory Default |
|----------------------|--|-----------------|
| RADIUS Server Enable | Enable or disable RADIUS Server | Disabled |
| Authentication Port | Specify the authentication port of the RADIUS server | 1812 |

RADIUS Client List

RADIUS Client List

Active

Client Name

IP Address

Subnet Mask

Share Key

Confirm Share Key

Add **Delete** **Modify**

Client List (0/64)

| Index | Active | Client Name | IP Address | Subnet Mask |
|-------|--------|-------------|------------|-------------|
|-------|--------|-------------|------------|-------------|

| Setting | Description | Factory Default |
|-------------------|---|-----------------|
| Active | Click to enable RADIUS Client configuration | Disabled |
| Client Name | Specify the client name for RADIUS client | 1812 |
| IP Address | Specify the IP Address where the RADIUS Client is located | 0.0.0.0 |
| Subnet Mask | Specify the Subnet Mask where the RADIUS Client is located | 0.0.0.0 |
| Share Key | Specify the share key which is identical to the one configured in the RADIUS Client | none |
| Confirm Share Key | Specify the confirm Share Key which is identical to the one configured in the RADIUS Client | none |

Authentication User List

Authentication User List

Active

User Name

Password

Confirm Password

Authority

Add **Delete** **Modify**

User List (0/64)

Index **Active** **User Name** **Authority**

| Setting | Description | Factory Default |
|------------------|---|-----------------|
| Active | Activate or deactivate authentication user list | Disabled |
| User Name | Specify the user name for the account | none |
| Password | Specify the password for the account | none |
| Confirm Password | Retype the account password to confirm | none |
| Authority | Specify the permission level of the account | Admin |

Port Access Control

The Moxa ToughNet Secure Router provides IEEE 802.1X port-based access control.

The IEEE 802.1X standard defines a protocol for client/server-based access control and authentication. The protocol restricts unauthorized clients from connecting to a LAN through ports that are open to the Internet, and which otherwise would be readily accessible. The purpose of the authentication server is to check each client that requests access to the port. The client is only allowed access to the port if the client's permission is authenticated.

Three components are used to create an authentication mechanism based on 802.1X standards: Client/Supplicant, Authentication Server, and Authenticator.

Client/Supplicant: The end station that requests access to the LAN and switch services and responds to the requests from the switch.

Authentication Server: The server that performs the actual authentication of the supplicant.

Authenticator: Edge switch or wireless access point that acts as a proxy between the supplicant and the authentication server, requesting identity information from the supplicant, verifying the information with the authentication server, and relaying a response to the supplicant.

The Moxa ToughNet Secure Router acts as an authenticator in the 802.1X environment. A supplicant and an authenticator exchange EAPOL (Extensible Authentication Protocol over LAN) frames with each other. We can either use an external RADIUS server as the authentication server, or implement the authentication server in the Moxa ToughNet Secure Router by using a Local User Database as the authentication look-up table. When we use an external RADIUS server as the authentication server, the authenticator and the authentication server exchange EAP frames between each other.

Authentication can be initiated either by the supplicant or the authenticator. When the supplicant initiates the authentication process, it sends an **EAPOL-Start** frame to the authenticator. When the authenticator initiates the authentication process or when it receives an **EAPOL-Start** frame, it sends an **EAP-Request/Identity** frame to ask for the username of the supplicant.

IEEE 802.1X Setting

802.1X Setting

Database Option Local ▼

Re-Auth Enable ▼

Re-Auth Period 3600

| Port | Enable |
|------|--------------------------|
| 1 | <input type="checkbox"/> |
| 2 | <input type="checkbox"/> |
| 3 | <input type="checkbox"/> |
| 4 | <input type="checkbox"/> |
| 5 | <input type="checkbox"/> |
| 6 | <input type="checkbox"/> |
| 7 | <input type="checkbox"/> |
| 8 | <input type="checkbox"/> |
| 9 | <input type="checkbox"/> |
| 10 | <input type="checkbox"/> |
| 11 | <input type="checkbox"/> |
| 12 | <input type="checkbox"/> |
| 13 | <input type="checkbox"/> |
| 14 | <input type="checkbox"/> |
| 15 | <input type="checkbox"/> |
| 16 | <input type="checkbox"/> |

Apply

Database Option

| Setting | Description | Factory Default |
|---------|--|-----------------|
| Local | Select this option to use the Local User Database as the authentication database, which supports up to 32 users. | Local |
| Radius | Select this option to set up an external RADIUS authentication database using EAP-MD5 authentication. | |

Re-Auth

| Setting | Description | Factory Default |
|----------------|---|-----------------|
| Enable/Disable | Enable or disable the requirement for clients to be re-authenticated after a specified duration of no activity. | Disable |

Re-Auth Period

| Setting | Description | Factory Default |
|-------------|--|-----------------|
| Time period | Specify the duration (in seconds) before clients are required to enter their username and password again. The range is between 60 and 65535. | 3600 |

802.1X

| Setting | Description | Factory Default |
|----------------|--|-----------------|
| Enable/Disable | Check the box for a port under the 802.1X column to enable IEEE 802.1X for that port. All end stations must enter usernames and passwords before access to these ports is allowed. | Disabled |

IEEE 802.1X Information

This page shows detailed IEEE 802.1X information including port, supplicant, user, and authenticator status.

802.1X Information

All ▾

| Port | Supplicant | User | Authenticator Status |
|------|------------|------|----------------------|
|------|------------|------|----------------------|

Authentication by Local Radius Server

RADIUS Server Setting

Authenticated by Local RADIUS Server

1st Server IP Address

1st Server Port

1st Server Share Key

2nd Server IP Address

2nd Server Port

2nd Server Share Key

Apply

Server Setting

| Setting | Description | Factory Default |
|--------------------------------------|---|-----------------|
| Authenticated by Local Radius Server | Enable or disable authentication by local radius server | Disabled |
| Server IP Address | The IP address of the RADIUS server. | 0.0.0.0 |
| Server Port | The port of the RADIUS server | 1812 |
| Server Share key | The shared key of the RADIUS server | None |

Local User Database

 **Local User Database**

User Name

Password

| Index | User Name |
|-------|-----------|
|-------|-----------|

Local User

| Setting | Description | Factory Default |
|-----------|---|-----------------|
| User Name | The user name of the local user account | None |
| Password | The password of the local user account | None |

10. Diagnosis

The ToughNet Secure Router provides **Ping** tools and **LLDP** for administrators to diagnose network systems. Additionally, **Process and Status Report** provides key device information for to facilitate troubleshooting.

Ping

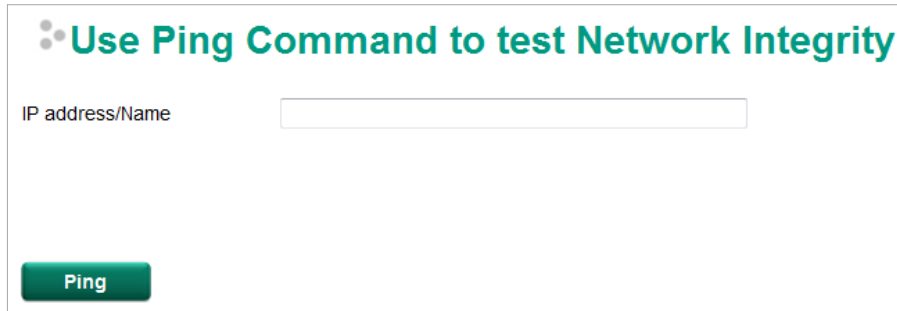

Use Ping Command to test Network Integrity

IP address/Name

Ping

The Ping function uses the ping command to give users a simple but powerful tool for troubleshooting network problems. The function's most unique feature is that even though the ping command is entered from the user's PC keyboard, the actual ping command originates from the ToughNet Secure Router itself. In this way, the user can essentially control the ToughNet Secure Router and send ping commands out through its ports. Just type in the desired IP address and click **Ping**, the router will send out the ping command to test the integrity of the network.

LLDP

LLDP Function Overview

Defined by IEEE 802.11AB, Link Layer Discovery Protocol (LLDP) is an OSI Layer 2 Protocol that standardizes the methodology of self-identity advertisement. It allows each networking device, such as a Moxa managed switch/router, to periodically inform its neighbors about itself and its configuration. In this way, all devices will be aware of each other.

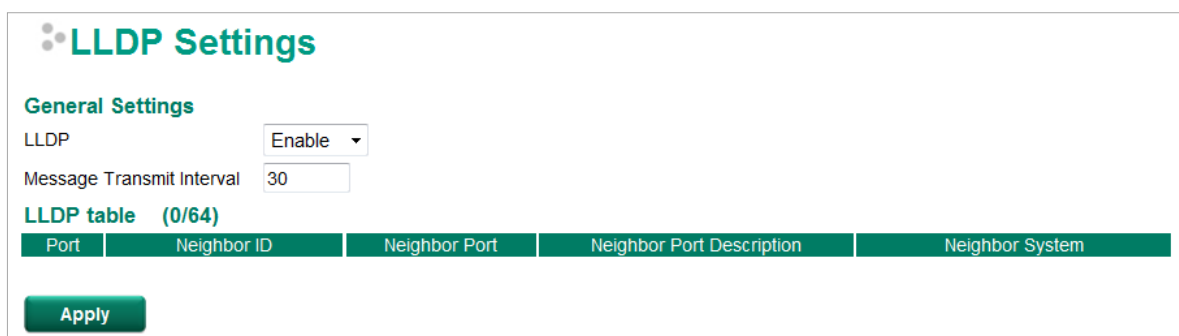

LLDP Settings

General Settings

LLDP

Message Transmit Interval

LLDP table (0/64)

| Port | Neighbor ID | Neighbor Port | Neighbor Port Description | Neighbor System |
|------|-------------|---------------|---------------------------|-----------------|
|------|-------------|---------------|---------------------------|-----------------|

Apply

The router's web interface can be used to enable or disable LLDP, and to set the LLDP **Message Transmit Interval**. Users can view each switch's neighbor-list, which is reported by its network neighbors.

LLDP Setting

Enable LLDP

| Setting | Description | Factory Default |
|--|---|-----------------|
| Enable/Disable/Enable & Ring Port Bypass | Enable or disable the LLDP function. When set to "Enable & Ring Port Bypass", no LLDP packets will be sent to neighbors, and LLDP will be bypassed from one ring port to another. | Enable |

Message Transmit Interval

| Setting | Description | Factory Default |
|-----------------|---|-----------------|
| 5 to 32768 sec. | Set the transmit interval of LLDP messages. Unit is in seconds. | 30 (sec.) |

LLDP Table

Port: The port number that connects to the neighbor device.

Neighbor ID: A unique entity that identifies a neighbor device; this is typically the MAC address.

Neighbor Port: The port number of the neighbor device.

Neighbor Port Description: A textual description of the neighbor device's interface.

Neighbor System: Hostname of the neighbor device.

Process and Status Report

Function Overview

Process and Status Report provides key device information that users can download in the form of a device process and status report to facilitate troubleshooting. To ensure proper use, contact Moxa technical support before using.

The report includes the following:

Network Status:

- LLDP (if it is enabled)
- Packets captured for 10 seconds
- Port usage information

System Status

- CPU usage
- Free Memory information
- Event log
- List of processes
- Configuration file of the router

Report information is collected under the following circumstances:

Auto collected, when:

- CPU usage alarm enabled, with CPU utilization exceeding the defined threshold and duration
- Port usage alarm enabled, with Port utilization exceeding the defined threshold and duration

Manually collected, when:

- Clicking **Export** under **Process and Status Report**.

The maximum number of reports is three, including the one generated when clicking the export button. Three reports will be compressed into one file.

Process and Status Report

Export

100 %



Process and Status Report

Click **Export**, and then the report will download when the progress bar reaches 100%.

A. MIB Groups

The ToughNet Secure Router comes with built-in SNMP (Simple Network Management Protocol) agent software that supports cold start trap, line up/down trap, and RFC 1213 MIB-II. The standard MIB groups that the ToughNet Secure Router series support are:

MIB II.1 – System Group

sysORTable

MIB II.2 – Interfaces Group

ifTable

MIB II.4 – IP Group

ipAddrTable

ipNetToMediaTable

IpGroup

IpBasicStatsGroup

IpStatsGroup

MIB II.5 – ICMP Group

IcmpGroup

IcmpInputStatus

IcmpOutputStats

MIB II.6 – TCP Group

tcpConnTable

TcpGroup

TcpStats

MIB II.7 – UDP Group

udpTable

UdpStats

MIB II.11 – SNMP Group

SnmpBasicGroup

SnmpInputStats

SnmpOutputStats

Public Traps

1. Cold Start

2. Link Up
3. Link Down
4. Authentication Failure

Private Traps:

1. Configuration Changed
2. Power On
3. Power Off

The ToughNet Secure Router also provides a MIB file, located in the file "Moxa-TN5916-MIB.my" on the ToughNet Secure Router Series utility CD-ROM for SNMP trap message interpretation.